

ELETTROPOMPE SOMMERGIBILI Submersible pumps

TL 65



POMPA - Pump	GIRI /Min - RPM.	POTENZA RESA NOMINALE Rated power (P _r)	ASSORBIMENTO NOMINALE Rated current 400 V.	FATTORE DI POTENZA Power factor	TENSIONE - Voltage	CONDENSATORE - Capacitor	CAVO - Cable	PASSAGGIO LIBERO Free passage	PESO - Weight
		kW	A	Cos. φ	50 Hz	μf	H07RNF 10mt.	mm	Kg
TL 618.6	960	0,9	3,4	0,77	3 ~ 400 V	-	4G2,5	60	45
TL 615			3,7	0,81					
TL 615 M-MB-MG	1450	1,5	10,5	-	1 ~ 230 V	40			
TL 617			3,7	0,81	3 ~ 400 V	-			
TL 617 M-MB-MG			10,5	-	1 ~ 230 V	40			
TL 618			4,5	0,81	-	-			
TL 612	2900	1,85	4	0,87	3 ~ 400 V	-	50		
TL 613			6,3			-			

M = Senza box di comando e condensatore, solo per utilizzo con apparecchiatura di comando dedicata EDOL 2 / M

Without control box and capacitor, only for use with dedicated control panel EDOL 2 / M

MB = Completa di box di comando, condensatore, protezione termica a riarmo manuale e interruttore luminoso

Complete of control box with capacitor, manual switch, thermal control and bright switch

MG = Completa di box di comando, condensatore, protezione termica a riarmo manuale e interruttore luminoso e regolatore di livello a galleggiante FOX 10

Complete of control box with capacitor, manual switch, thermal control, bright switch and float switch FOX 10

GIRANTE VORTEX - Vortex impeller

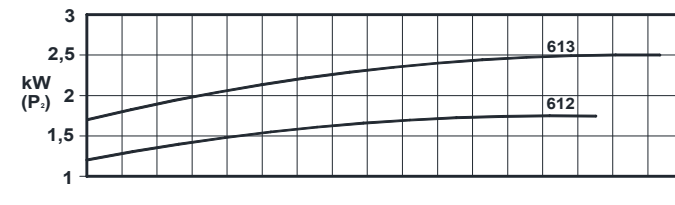
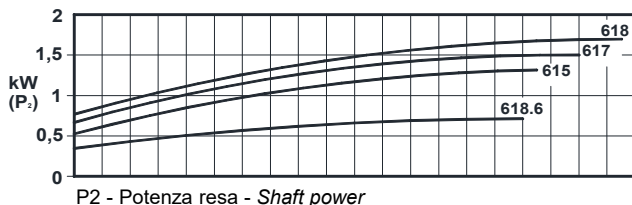
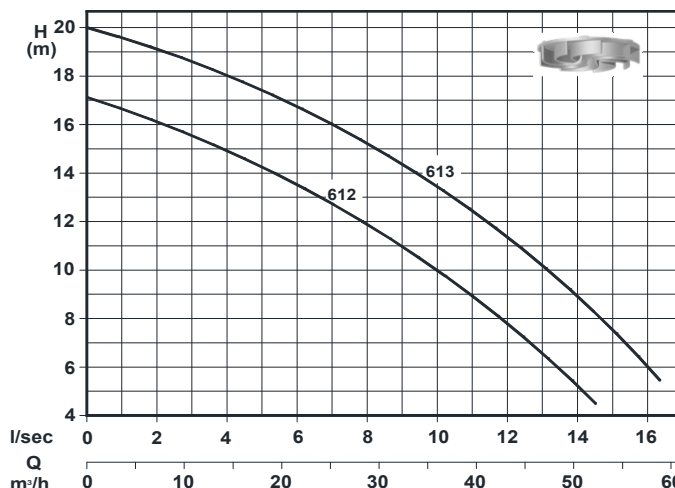
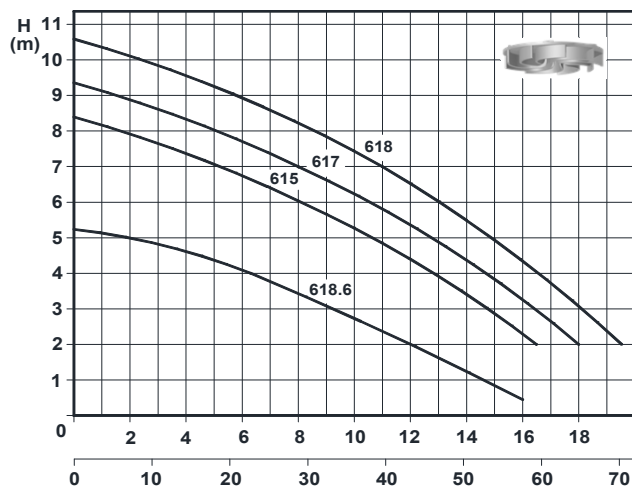

Curve secondo ISO 9906 Liv. 2

DESCRIZIONE - Description

Elettropompa sommersibile con girante vortex.
Doppia tenuta in camera olio.
Temperatura max. del liquido: 40°C.
Submersible electric pumps with vortex impeller.
Double mechanical seal in oil-chamber.
Max liquid temperature 40°C.

IMPIEGHI - Application

Sollevamento di acque luride grezze, fanghi biologici, acque reflue industriali e acque piovane.
For pumping dirty water, sewage, biological muds, ground water, rain water and industrial effluent.

COSTRUZIONE - Materials

Fusioni principali : Ghisa G 20
Principal parts : Cast iron G 20
Girante : Ghisa G 20
Impeller : Cast iron G 20
Albero : Acciaio inox AISI 420
Shaft : Stainless steel AISI 420
Viteria : Acciaio inox AISI 304
Screws : Stainless steel AISI 304

CUSCINETTI - Bearings

A sfere lubrificati a vita.
Single-row deep groove ball bearings.

DIMENSIONI DI INGOMBRO - Overall Dimensions

INSTALLAZIONE MOBILE - Mobile Installation

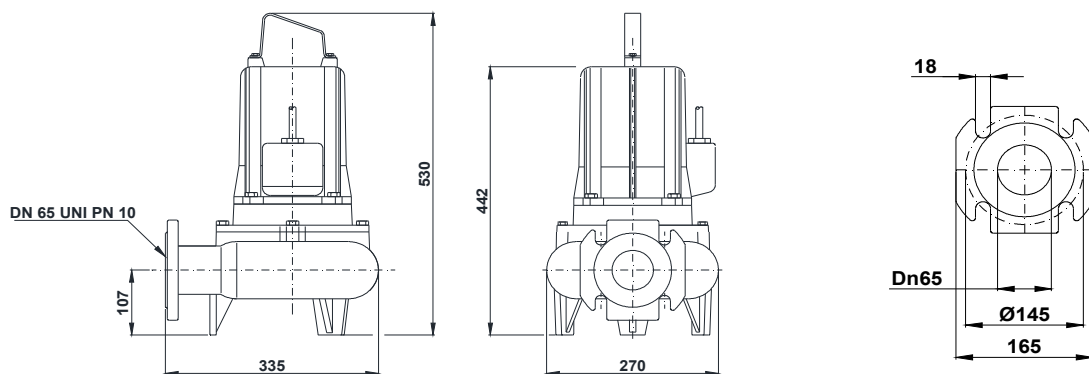

INSTALLAZIONE FISSA - Fixed installation

DISPOSITIVO DI ACCOPPIAMENTO DN 65C

Discharge connection bracket DN 65C

DISPOSITIVO DI ACCOPPIAMENTO DN 65/80 D

Discharge connection bracket DN 65/80 D

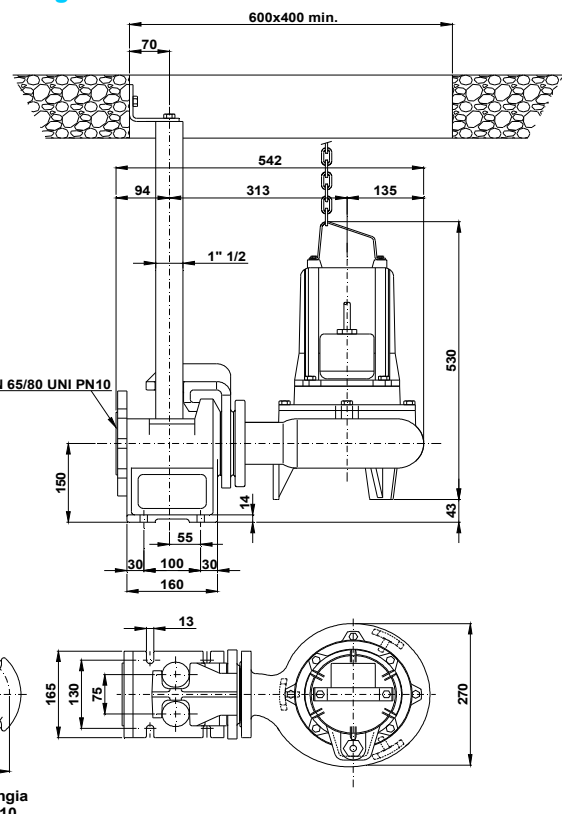
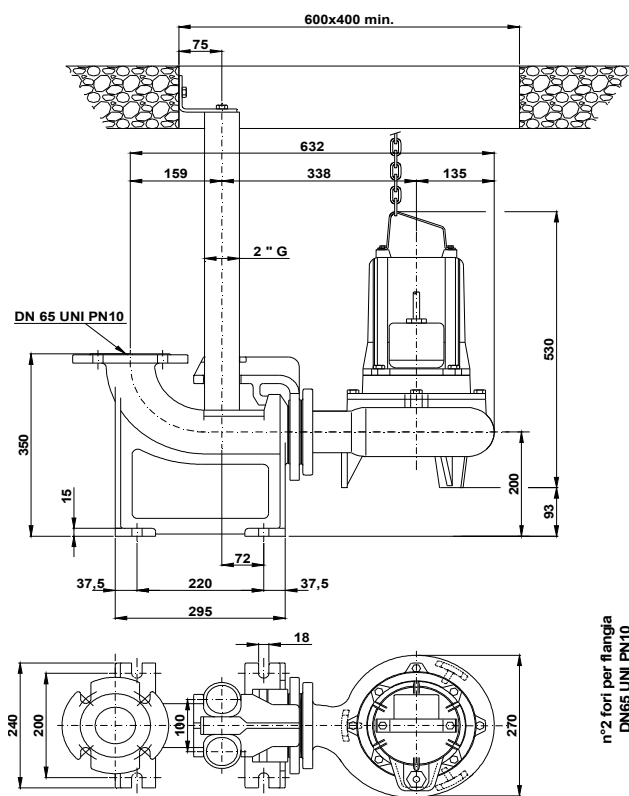

Con riserva di variazioni tecniche e costruttive senza preavviso.

With reserve of technical and constructive variations without warning. Avec réserve de variations techniques et constructives sans préavis

POMPE ROTOMECC s.r.l. - 20063 CERNUSCO SUL NAVIGLIO (MI) - ITALY - Via Ponchielli, 1

Tel. 02 9211.0205 - 02 9233.0399 Fax 02 9211.0630 Sito Internet: www.pomperotomec.it E-mail: sales@pomperotomec.it