



POMPE ROTOMECC

Elettropompe centrifuge ad asse orizzontale con girante arretrata a vortice
Centrifugal horizontal pumps with vortex impeller
Pompes à axe horizontal avec roue vortex

KS 150/6-280.1

DN 150

Giri/1' - r.p.m.
960



UNI EN ISO 9001 - 2015

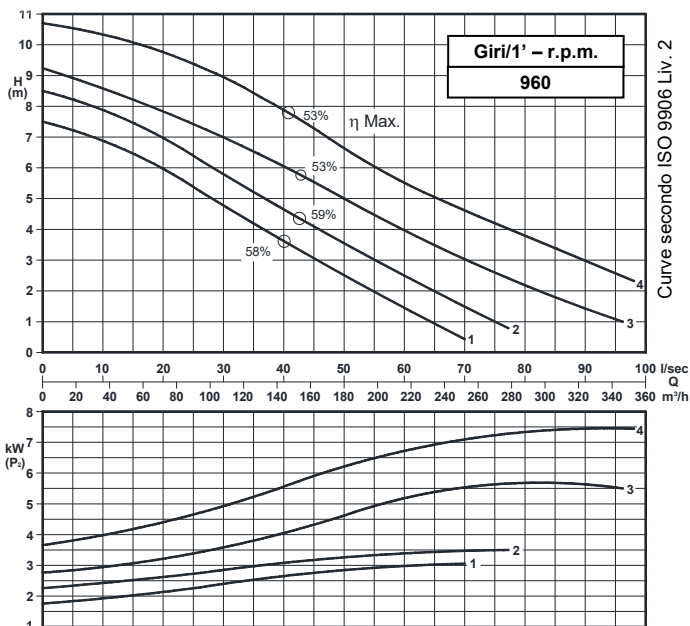

Grandezza - Size - Group 150/280

Curva Curve Courbe N°	Pompa Pump Pompe	DN	Potenza motore Motor power Puissance du moteur P2 (Kw)	Giri/1' r.p.m.	Passaggio libero Free passage Section de passage
1	KS 150/6-269F4 A3 S2	150	4	960	120
2	KS 150/6-274F4 A3 S2				
3	KS 150/6-250E A3 S2				130
4	KS 150/6-275E A3 S2				

P2 - Potenza resa - Shaft power - Puissance sur arbre

COSTRUZIONE - Materials - Matériaux

Fusioni principali - Principal parts - Parts principal	Ghisa - Cast iron - Fonte - GG 25
Girante - Impeller - Roue	Ghisa - Cast iron - Fonte GS 500 (F4 - H1) - GG25 (E1)
Albero - Shaft - Arbre	AISI 420
Viteria - Screws - Vis	AISI 304

TENUTE MECCANICHE - Mechanical seals - Garniture mécanique

Doppia tenuta meccanica in bagno d'olio - Double mechanical seals in oil bath - Double garniture mécanique en chambre d'huile
Tenuta lato motore / tenuta lato liquido : carburo di silicio <i>Motor side / liquid side mechanical seal : silicon carbide</i> <i>Garniture mécanique côté du moteur / côté liquide : carbure de silicium</i>

CARATTERISTICHE TECNICHE - Technical Features - Caractéristiques Techniques

Max. temperatura liquido - Max. liquid temp. - Max. temperature du liquide : 60°C
pH Liquido pompato - pH pumped liquid - pH du liquide pompé : 6 - 10

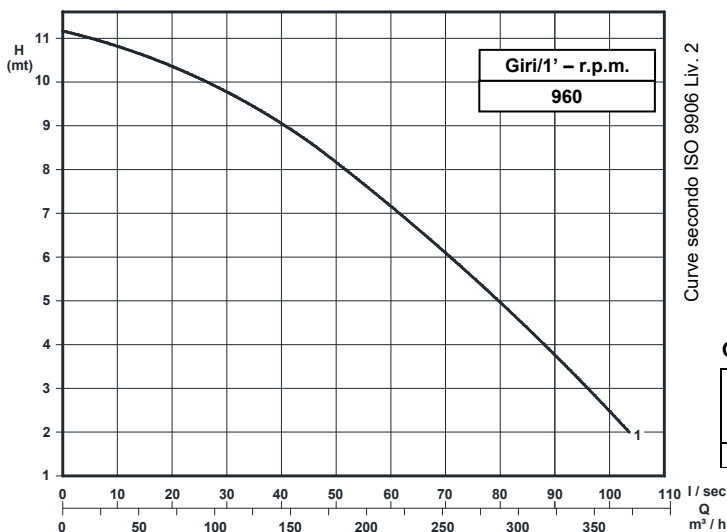

Grandezza - Size - Group 150/280

Curva Curve Courbe N°	Pompa Pump Pompe	DN	Potenza motore Motor power Puissance du moteur P2 (Kw)	Giri/1' r.p.m.	Passaggio libero Free passage Section de passage
1	KS 150/6-279H A3 S2	150	11	960	125

P2 - Potenza resa - Shaft power - Puissance sur arbre

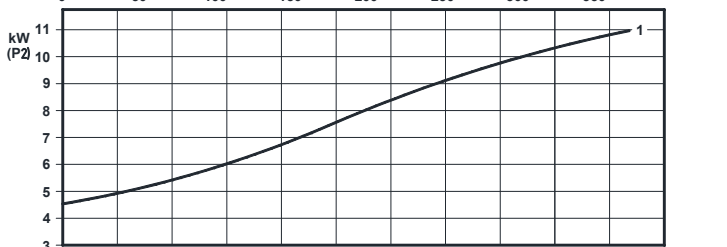

DIMENSIONI DI INGOMBRO – Dimensions

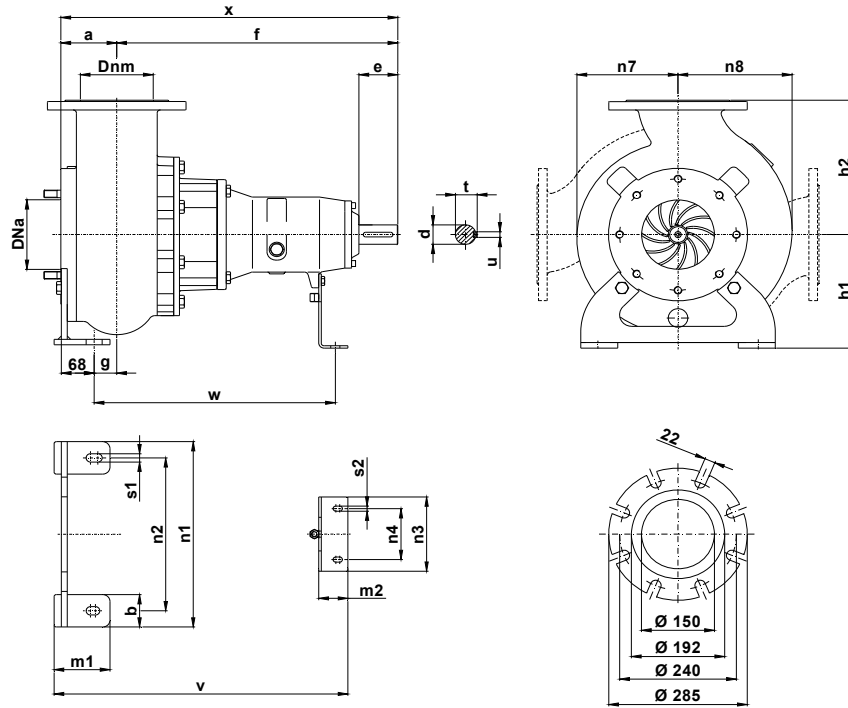

Pompa Pump Pompe	DNa DNm	a	b	c	d	e	f	g	h1	h2	m1	m2	n1	n2	n3	n4	n7	n8	s1	s2	t	u	v	w	x	Peso Weight Poids
KS 150 / .. A3S2	150	115	70	12	42	80	578	47	245	290	115	60	400	330	150	110	210	240	18	11	45	12	605	500	693	128

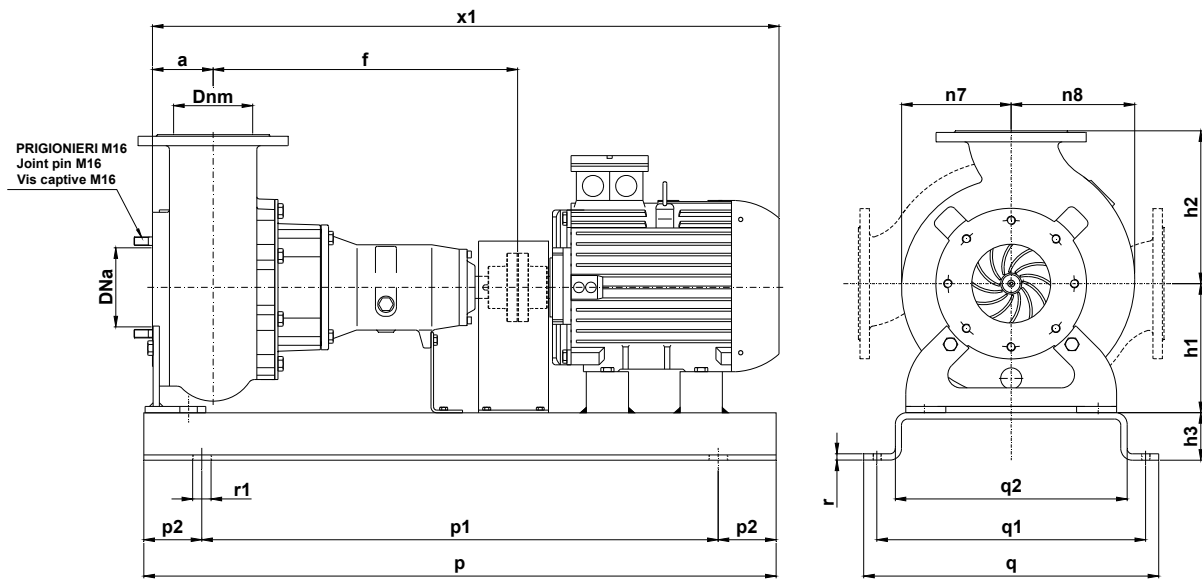

Pompa Pump Pompe	kW	Giri/1' r.p.m.	Motore Motor - Moteur MEC	h3	p	p1	p2	q	q1	q2	r	r1	x1	Peso Weight Poids
KS 150/6-269F4 A3 S2	4	960	132	100	1000	800	100	560	510	440	12	18	1210	267
KS 150/6-274F4 A3 S2								564	510	440				298
KS 150/6-250E A3 S2	5,5		160*		1350	1150	600	564	-	1358	353			
KS 150/6-275E A3 S2	7,5													
KS 150/6-279H A3 S2	11													

KS 150/6-280.1.19

*Basamento in acciaio profilato saldato – Profiled welded steel base – Profilé de base en acier soudé

Con riserva di variazioni tecniche e costruttive senza preavviso.
With reserve of technical and constructive variations without warning. – Avec réserve de variations techniques et constructives sans préavis.

POMPE ROTOMECC srl - 20063 CERNUSCO SUL NAVIGLIO (MI) - ITALY - Via Ponchielli,1

+39.02.92110205 - +039.02.92330399 +39.02.92110630 Sito Internet: www.pomperotomec.it E-mail: sales@pomperotomec.it



POMPE ROTOMECC

Elettropompe centrifughe ad asse orizzontale con girante arretrata a vortice
Centrifugal horizontal pumps with vortex impeller
Pompes à axe horizontal avec roue vortex

KS 150/6-375.1

DN 150

Giri/1' - r.p.m. 960



UNI EN ISO 9001 - 2015

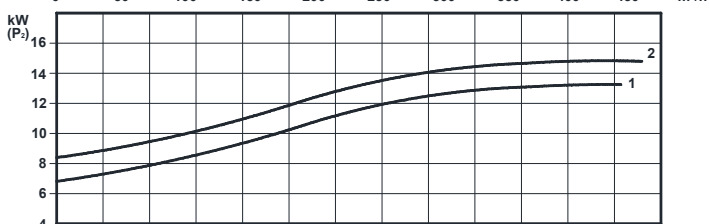
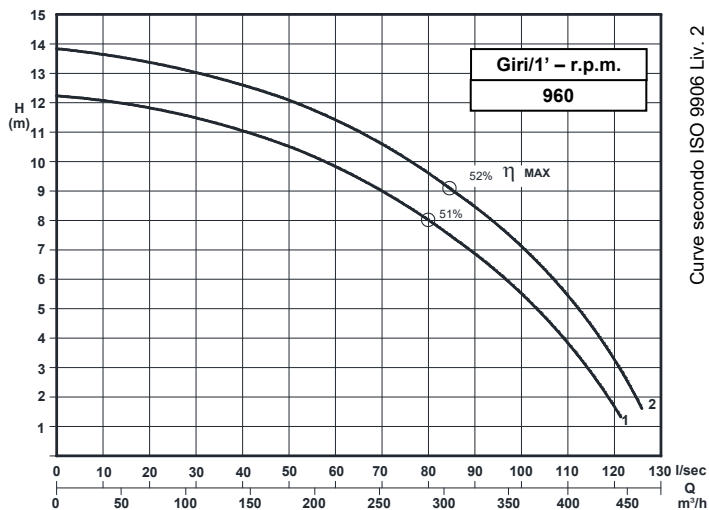

Grandezza - Size - Group 150/280

Curva Curve Courbe N°	Pompa Pump Pompe	DN	Potenza motore Motor power P2 (Kw)	Giri/1' r.p.m.	Passaggio libero Free passage Section de passage
1	KS 150/6-340K11 A4 S3	150	15	960	120
2	KS 150/6-355K11 A4S3				

P2 - Potenza resa - Shaft power - Puissance sur arbre

COSTRUZIONE - Materials - Matériaux

Fusioni principali - Principal parts - Parts principal	Ghisa - Cast iron - Fonte - GG 25
Girante - Impeller - Roue	Ghisa - Cast iron - Fonte - GS 500
Albero - Shaft - Arbre	AISI 420
Viteria - Screws - Vis	AISI 304

TENUTE MECCANICHE - Mechanical seals - Garniture mécanique

Doppia tenuta meccanica in bagno d'olio - Double mechanical seals in oil bath - Double garniture mécanique en chambre d'huile
Tenuta lato motore / tenuta lato liquido : carburo di silicio Motor side / liquid side mechanical seal : silicon carbide Garniture mécanique côté du moteur / côté liquide : carbure de silicium

CARATTERISTICHE TECNICHE - Technical Features - Caractéristiques Techniques

Max. temperatura liquido - Max. liquid temp. - Max. temperature du liquide : 60°C
pH Liquido pompato - pH pumped liquid - pH du liquide pompé : 6 - 10

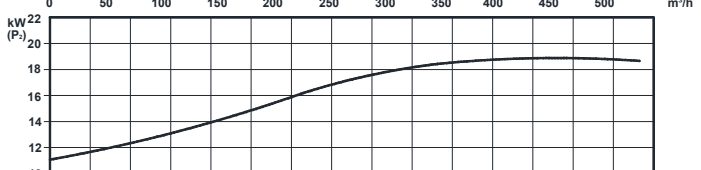
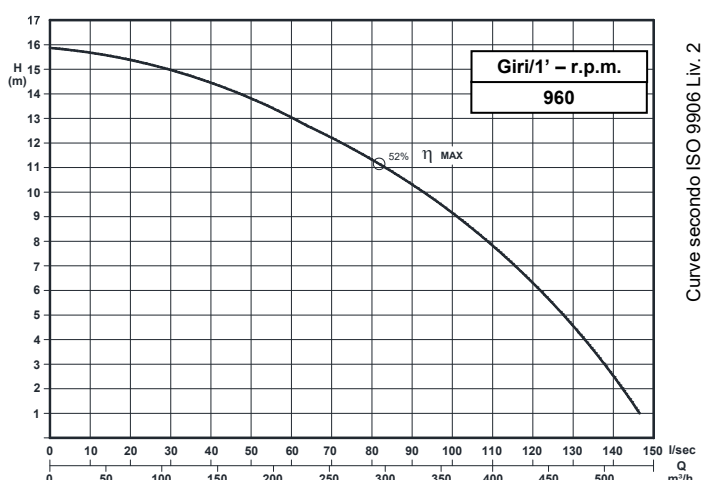

Grandezza - Size - Group 150/280

Curva Curve Courbe N°	Pompa Pump Pompe	DN	Potenza motore Motor power P2 (Kw)	Giri/1' r.p.m.	Passaggio libero Free passage Section de passage
1	KS 150/6-374K11 A4 S3	150	22	960	120

P2 - Potenza resa - Shaft power - Puissance sur arbre

DIMENSIONI DI INGOMBRO – Dimensions

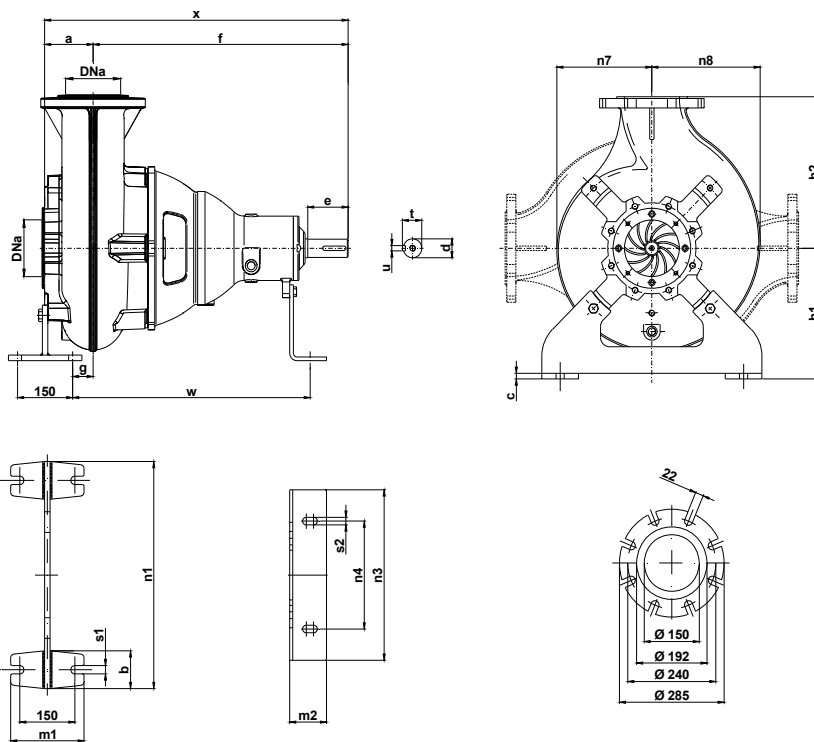

Pompa Pump Pompe	DNa DNm	a	b	c	d	e	f	g	h1	h2	m1	m2	n1	n2	n3	n4	n7	n8	s1	s2	t	u	v	w	x	Peso Weight Poids
KS 150 / .. A4S3	150	135	100	12	42	110	692	53	345	400	200	100	400	330	150	110	210	240	22	20	53	14	860	641	827	220

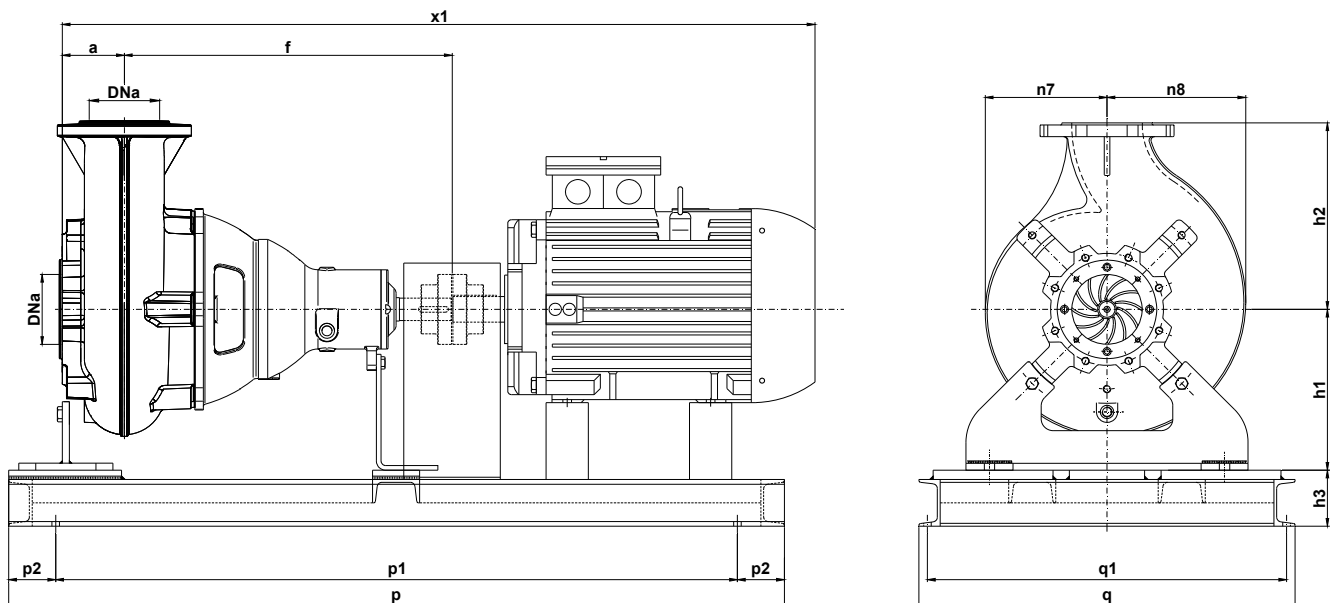

Pompa Pump Pompe	kW	Giri/1' r.p.m.	Motore Motor - Moteur MEC	h3	p	p1	p2	q	q1	x1	Peso Weight Poids
KS 150/6-340K11 A4 S3	15	960	200	100	1650	1450	100	800	765	1550	484
KS 150/6-355K11 A4S3										1600	560
KS 150/6-374K11 A4 S3	22										

KS 150-375.1.19

Con riserva di variazioni tecniche e costruttive senza preavviso.
With reserve of technical and constructive variations without warning. – Avec réserve de variations techniques et constructives sans préavis.

POMPE ROTOMECC srl - 20063 CERNUSCO SUL NAVIGLIO (MI) - ITALY - Via Ponchielli,1

+39.02.92110205 - +39.02.92330399 +39.02.92110630 **Sito Internet:** www.pomperotomec.it **E-mail:** sales@pomperotomec.it



POMPE ROTOMECC

Elettropompe centrifughe ad asse orizzontale con girante arretrata a vortice
Centrifugal horizontal pumps with vortex impeller
Pompes à axe horizontal avec roue vortex

KS 150/4-280.1

DN 150

Giri/1' - r.p.m.
1450



UNI EN ISO 9001 - 2015

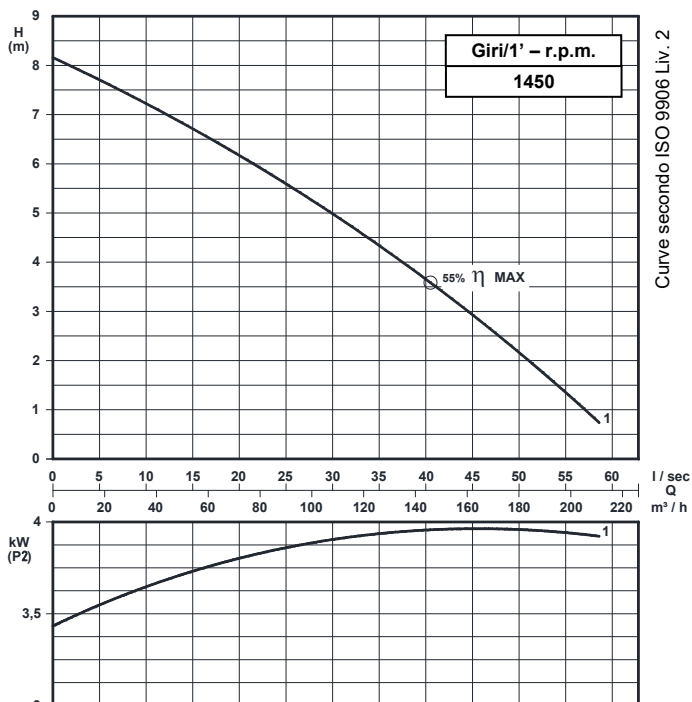
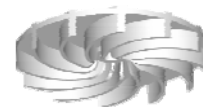

Grandezza - Size - Group 150/280

Curva Curve Courbe N°	Pompa Pump Pompe	DN	Potenza motore Motor power Puissance du moteur P2 (Kw)	Giri/1' r.p.m.	Passaggio libero Free passage Section de passage
1	KS 150-216N7 A3 S2	150	4	1450	115

P2 - Potenza resa - Shaft power - Puissance sur arbre

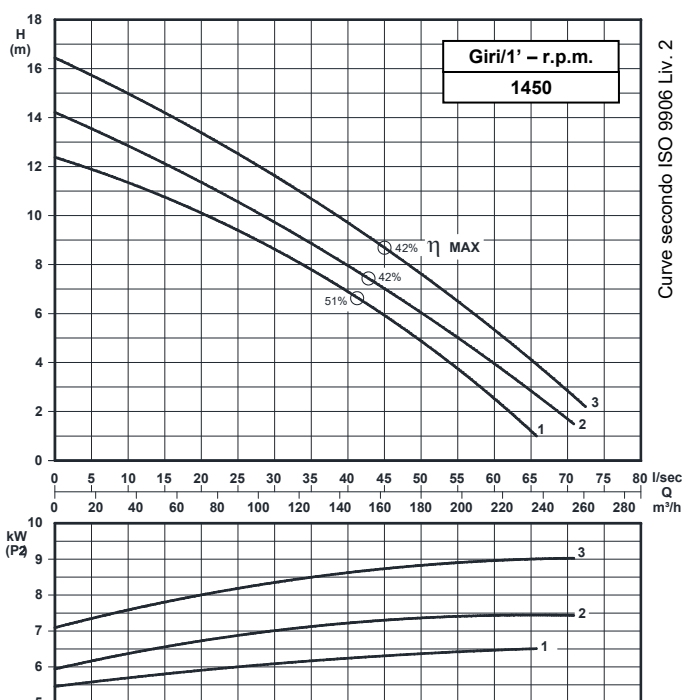

Grandezza - Size - Group 150/280

Curva Curve Courbe N°	Pompa Pump Pompe	DN	Potenza motore Motor power Puissance du moteur P2 (Kw)	Giri/1' r.p.m.	Passaggio libero Free passage Section de passage
1	KS 150-254N8 A3 S2	150	7,5	1450	120
2	KS 150-258N8 A3 S2				
3	KS 150-265N4 A3 S2				

P2 - Potenza resa - Shaft power - Puissance sur arbre

COSTRUZIONE - Materials - Matériaux	
Fusioni principali - Principal parts - Parts principal	Ghisa - Cast iron - Fonte - GG 25
Girante - Impeller - Roue	Ghisa - Cast iron - Fonte - GG 25
Albero - Shaft - Arbre	AISI 420
Viteria - Screws - Vis	AISI 304

TENUTE MECCANICHE - Mechanical seals - Garniture mécanique
Doppia tenuta meccanica in bagno d'olio - Double mechanical seals in oil bath - Double garniture mécanique en chambre d'huile
Tenuta lato motore / tenuta lato liquido : carburo di silicio
Motor side / liquid side mechanical seal : silicon carbide
Garniture mécanique côté du moteur / côté liquide : carbure de silicium

CARATTERISTICHE TECNICHE - Technical Features - Caractéristiques Techniques
Max. temperatura liquido - Max. liquid temp. - Max. temperature du liquide : 60°C
pH Liquido pompato - pH pumped liquid - pH du liquide pompé : 6 - 10

DIMENSIONI DI INGOMBRO - Dimensions

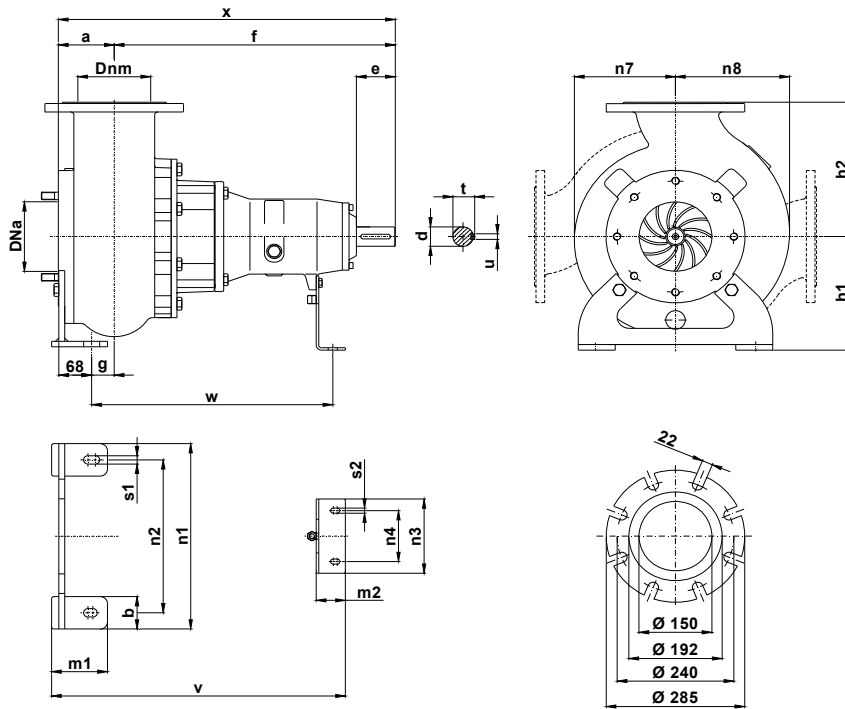

Pompa Pump Pompe	DNa DNm	a	b	c	d	e	f	g	h1	h2	m1	m2	n1	n2	n3	n4	n7	n8	s1	s2	t	u	v	w	x	Peso Weight Poids
KS 150 / .. A3S2	150	115	70	12	42	80	578	46	245	290	115	60	400	330	160	110	210	240	18	11	45	12	605	500	693	128

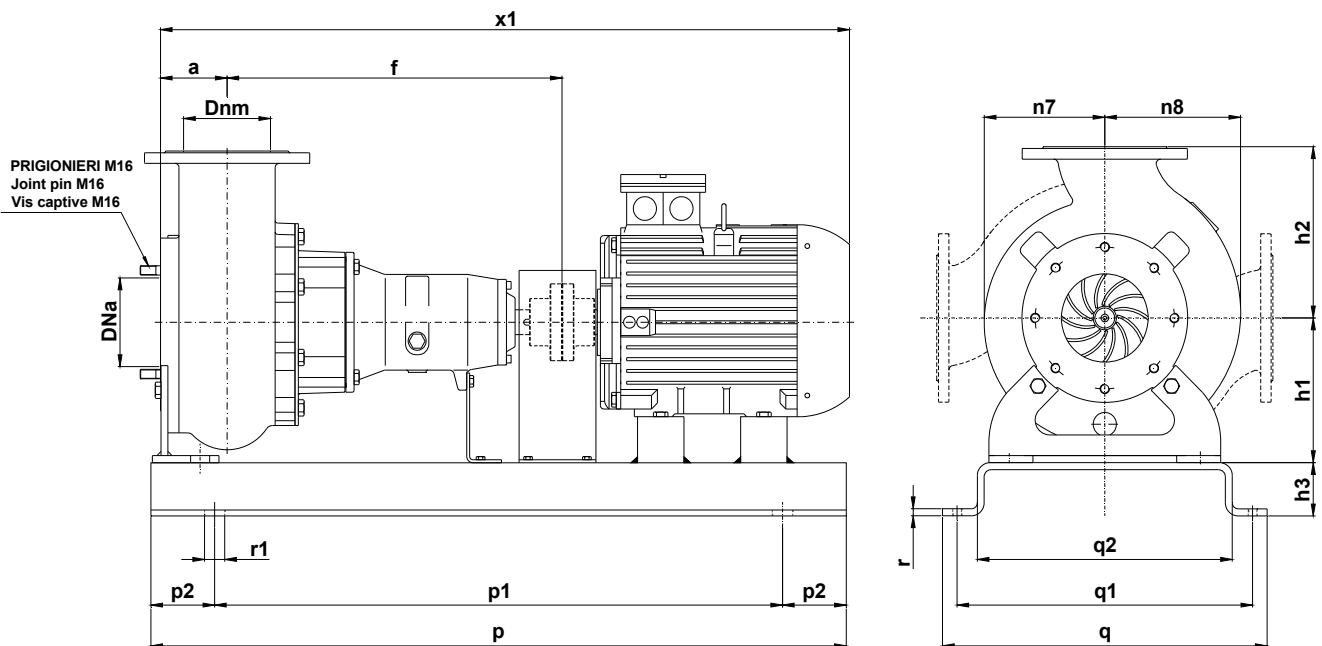

Pompa Pump Pompe	kW	Giri/1' r.p.m.	Motore Motor - Moteur MEC	h3	p	p1	p2	q	q1	q2	r	r1	x1	Peso Weight Poids
KS 150-214N7 A3 S2	4	1450	112	70	1000	800	100	540	490	440	10	18	1100	267
KS 150-254N8 A3 S2	7,5		132	90	1200	100		560	510		12		1210	298
KS 150-258N8 A3 S2	11		160*	120	1350	1150		600	564	-	-		1305	353
KS 150-265N4 A3 S2														

*Basamento in acciaio profilato saldato – Profiled welded steel base – Profilé de base en acier soudé

KS 150/4-280.1.19

Con riserva di variazioni tecniche e costruttive senza preavviso.

With reserve of technical and constructive variations without warning. – Avec réserve de variations techniques et constructives sans préavis.

POMPE ROTOMECC srl - 20063 CERNUSCO SUL NAVIGLIO (MI) - ITALY - Via Ponchielli,1

+39.02.92110205 - +39.02.92330399 +39.02.92110630 **Sito Internet:** www.pomperotomec.it **E-mail:** sales@pomperotomec.it



POMPE ROTOMECC

Elettropompe centrifughe ad asse orizzontale con girante arretrata a vortice
Centrifugal horizontal pumps with vortex impeller
Pompes à axe horizontal avec roue vortex

KS 150/4-280.2

DN 150

Giri/1' - r.p.m.
1450



UNI EN ISO 9001 - 2015

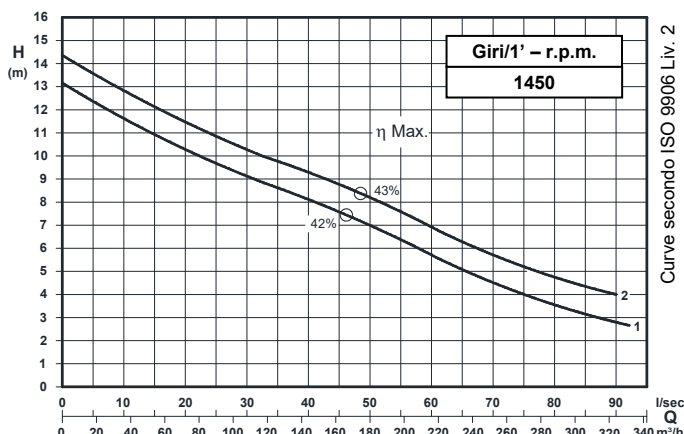

Grandezza - Size - Group 150/280

Curva Curve Courbe N°	Pompa Pump Pompe	DN	Potenza motore Motor power Puissance du moteur P2 (Kw)	Giri/1' r.p.m.	Passaggio libero Free passage Section de passage
1	KS 150-230F4 A3 S2	150	11	1450	130
2	KS 150-240F4 A3 S2				

P2 - Potenza resa - Shaft power - Puissance sur arbre

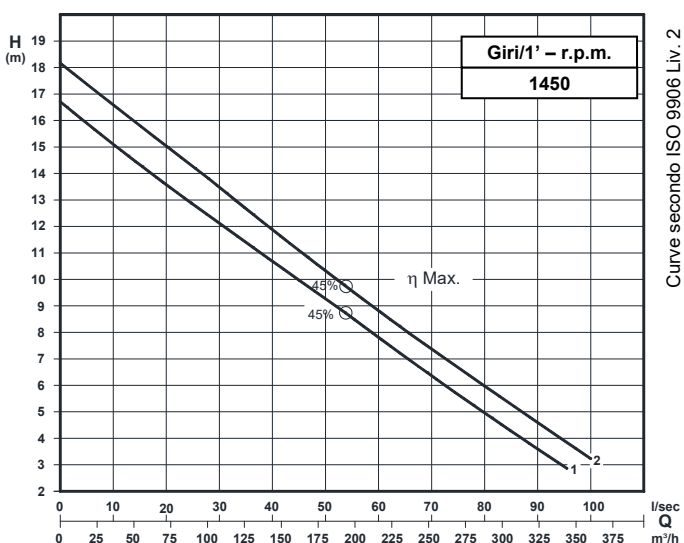
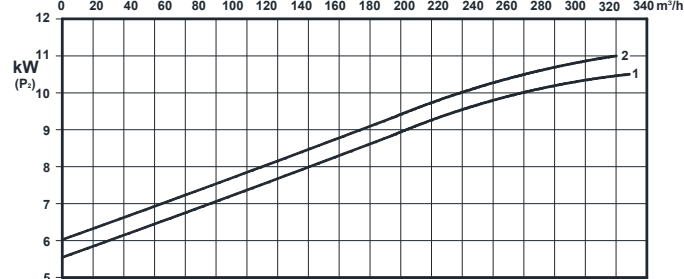

Grandezza - Size - Group 150/280

Curva Curve Courbe N°	Pompa Pump Pompe	DN	Potenza motore Motor power Puissance du moteur P2 (Kw)	Giri/1' r.p.m.	Passaggio libero Free passage Section de passage
1	KS 150-245F4 A3 S2	150	15	1450	130
2	KS 150-255F4 A3 S2				

P2 - Potenza resa - Shaft power - Puissance sur arbre



COSTRUZIONE - Materials - Matériaux	
Fusioni principali - Principal parts - Parts principal	Ghisa - Cast iron - Fonte - GG 25
Girante - Impeller - Roue	Ghisa - Cast iron - Fonte - GS 500
Albero - Shaft - Arbre	AISI 420
Viteria - Screws - Vis	AISI 304

TENUTE MECCANICHE - Mechanical seals - Garniture mécanique
Doppia tenuta meccanica in bagno d'olio - Double mechanical seals in oil bath - Double garniture mécanique en chambre d'huile
Tenuta lato motore / tenuta lato liquido : carburo di silicio Motor side / liquid side mechanical seal : silicon carbide
Garniture mécanique côté du moteur / côté liquide : carbure de silicium

CARATTERISTICHE TECNICHE - Technical Features - Caractéristiques Techniques
Max. temperatura liquido - Max. liquid temp. - Max. temperature du liquide : 60°C
pH Liquido pompato - pH pumped liquid - pH du liquide pompé : 6 - 10

DIMENSIONI DI INGOMBRO – Dimensions

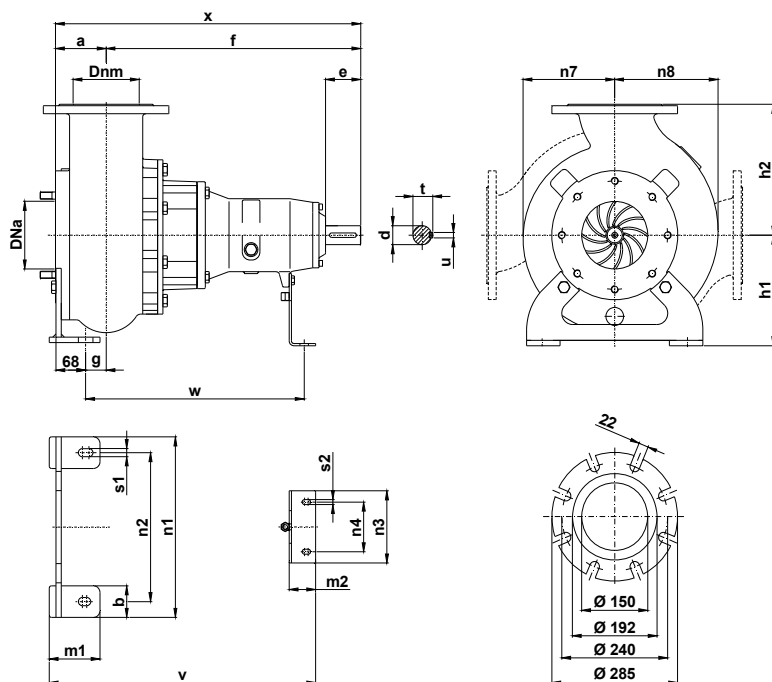

Pompa Pump Pompe	DNa DNm	a	b	c	d	e	f	g	h1	h2	m1	m2	n1	n2	n3	n4	n7	n8	s1	s2	t	u	v	w	x	Peso Weight Poids
KS 150 / .. A3S2	150	115	70	12	42	80	578	47	245	290	115	60	400	330	150	110	210	240	18	11	45	12	605	500	693	128

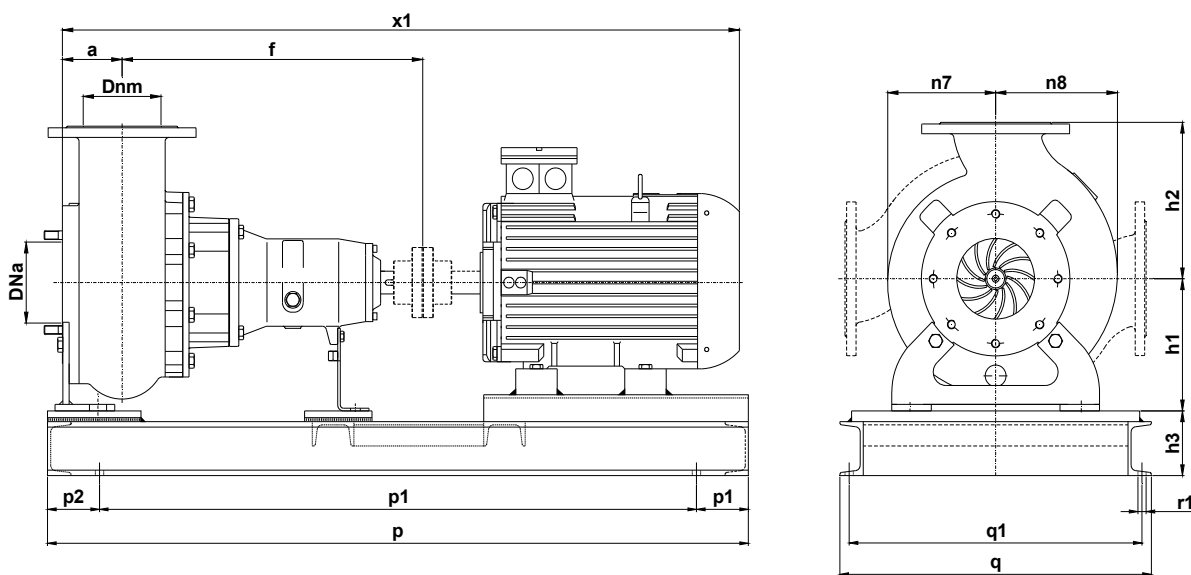

Pompa Pump Pompe	kW	Giri/1' r.p.m.	Motore Motor - Moteur MEC	h3	p	p1	p2	q	q1	r1	x1	Peso Weight Poids
KS 150-230F4 A3 S2	11	1450	160	120	1350	1150	100	600	564	18	1305	353
KS 150-240F4 A3 S2												
KS 150-245F4 A3 S2	15	1450	160	120	1350	1150	100	600	564	18	1345	373
KS 150-255F4 A3 S2												

KS 150/4-280.2.19

Con riserva di variazioni tecniche e costruttive senza preavviso.
With reserve of technical and constructive variations without warning. – Avec réserve de variations techniques et constructives sans préavis.

POMPE ROTOMECC srl - 20063 CERNUSCO SUL NAVIGLIO (MI) - ITALY - Via Ponchielli,1

+39.02.92110205 - +39.02.92330399 +39.02.92110630 **Sito Internet:** www.pomperotomec.it **E-mail:** sales@pomperotomec.it



POMPE ROTOMECC

Elettropompe centrifughe ad asse orizzontale con girante arretrata a vortice
Centrifugal horizontal pumps with vortex impeller
Pompes à axe horizontal avec roue vortex

KS 150/4-280.3

DN 150

Giri/1' - r.p.m.
1450



UNI EN ISO 9001 - 2015

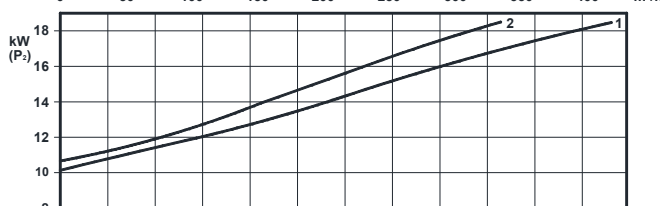
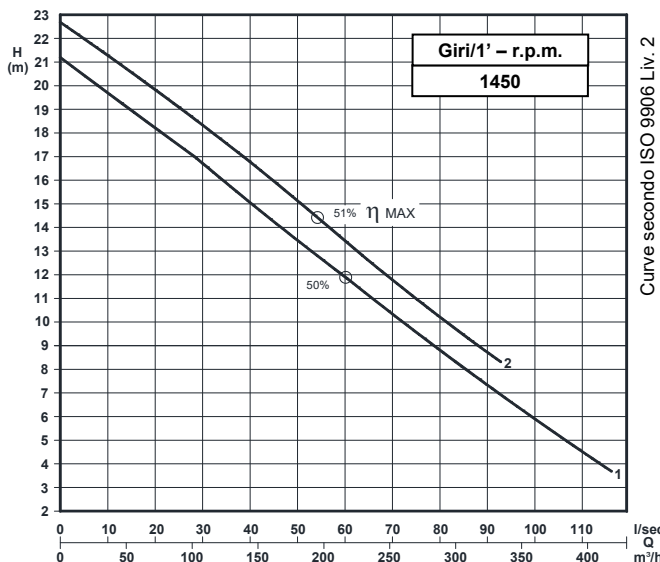
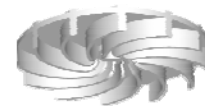

Grandezza - Size - Group 150/280

Curva Curve Courbe N°	Pompa Pump Pompe	DN	Potenza motore Motor power Puissance du moteur P2 (Kw)	Giri/1' r.p.m.	Passaggio libero Free passage Section de passage
1	KS 150-274F4 A3 S2	150	18,5	1450	120
2	KS 150-279F4 A3 S2				

P2 - Potenza resa - Shaft power - Puissance sur arbre

COSTRUZIONE - Materials - Matériaux	
Fusioni principali - Principal parts - Parts principal	Ghisa - Cast iron - Fonte - GG 25
Girante - Impeller - Roue	Ghisa - Cast iron - Fonte - GS 500
Albero - Shaft - Arbre	AISI 420
Viteria - Screws - Vis	AISI 304

TENUTE MECCANICHE - Mechanical seals - Garniture mécanique
Doppia tenuta meccanica in bagno d'olio - Double mechanical seals in oil bath - Double garniture mécanique en chambre d'huile
Tenuta lato motore / tenuta lato liquido : carburo di silicio Motor side / liquid side mechanical seal : silicon carbide
Garniture mécanique côté du moteur / côté liquide : carbure de silicium

CARATTERISTICHE TECNICHE - Technical Features - Caractéristiques Techniques
Max. temperatura liquido - Max. liquid temp. - Max. temperature du liquide : 60°C
pH Liquido pompato - pH pumped liquid - pH du liquide pompé : 6 - 10

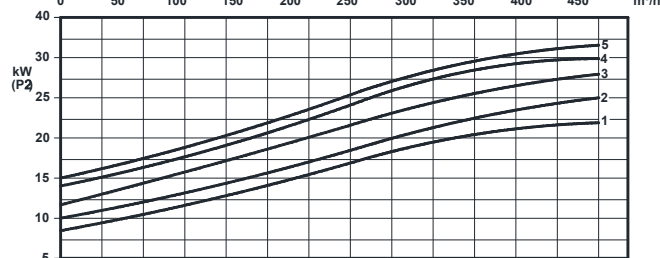
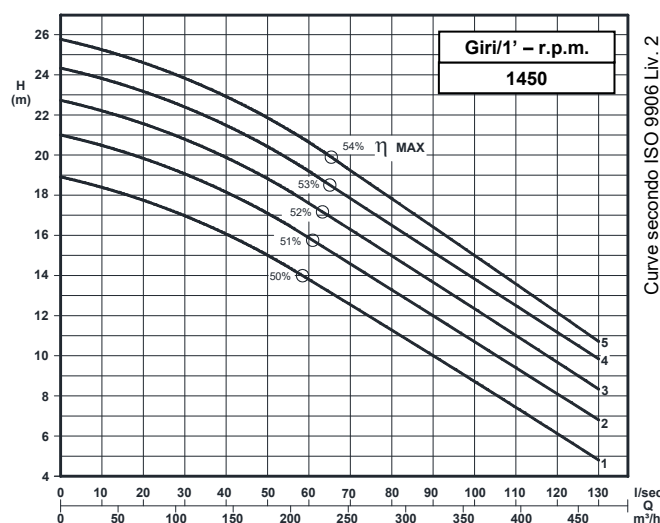

Grandezza - Size - Group 150/280

Curva Curve Courbe N°	Pompa Pump Pompe	DN	Potenza motore Motor power Puissance du moteur P2 (Kw)	Giri/1' r.p.m.	Passaggio libero Free passage Section de passage
1	KS 150-240H A3 S2	150	30	1450	125
2	KS 150-250H A3 S2				
3	KS 150-260H A3 S2				
4	KS 150-270H A3 S2		37		
5	KS 150-279H A3 S2				

P2 - Potenza resa - Shaft power - Puissance sur arbre

DIMENSIONI DI INGOMBRO - Dimensions

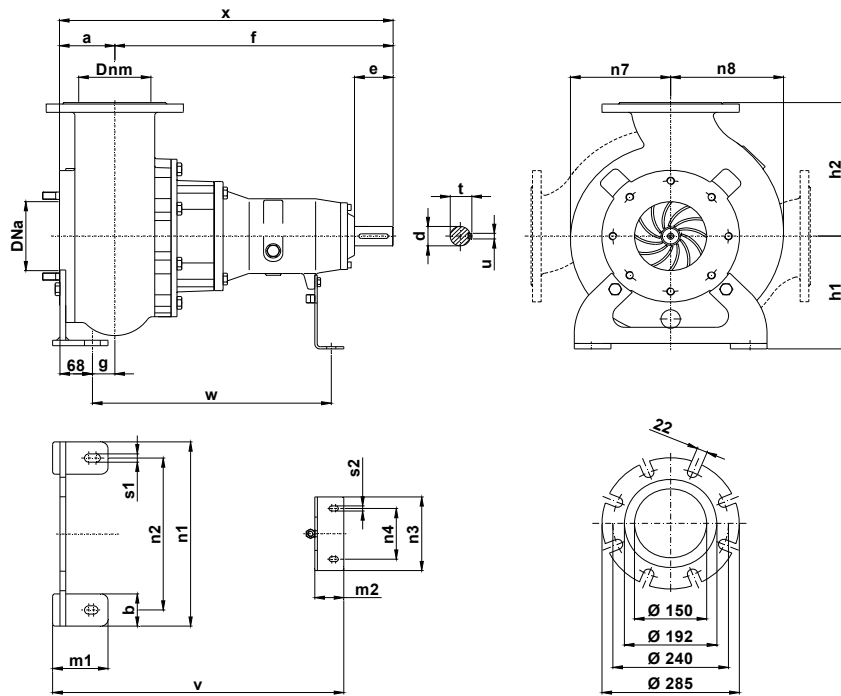

Pompa Pump Pompe	DNa DNm	a	b	c	d	e	f	g	h1	h2	m1	m2	n1	n2	n3	n4	n7	n8	s1	s2	t	u	v	w	x	Peso Weight Poids
KS 150 / .. A3S2	150	115	70	12	42	80	578	47	245	290	115	60	400	330	150	110	210	240	18	11	45	12	605	500	693	128

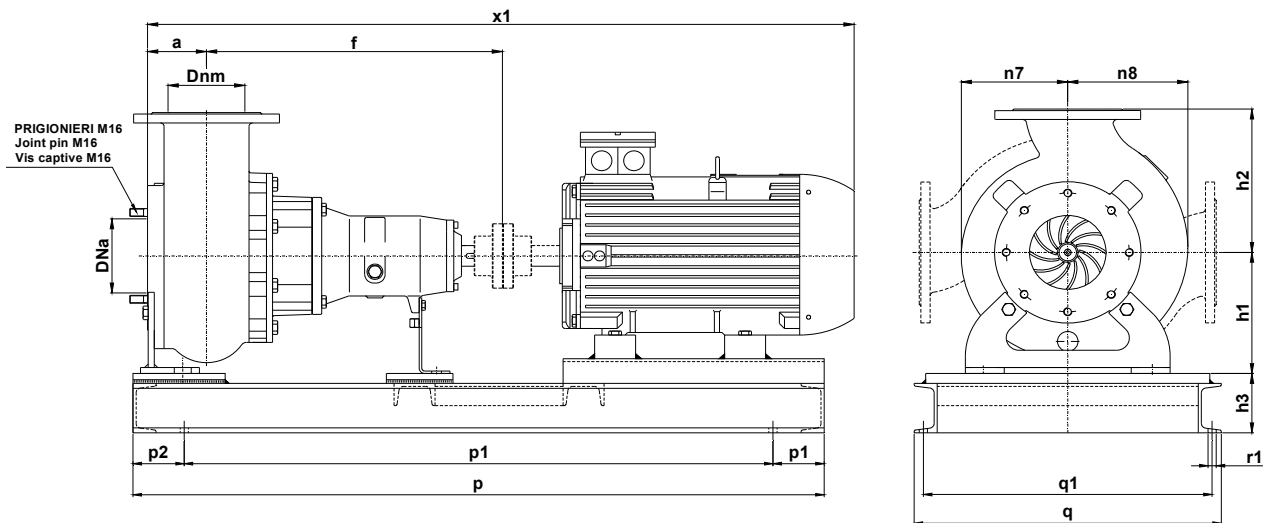

Pompa Pump Pompe	kW	Giri/1' r.p.m.	Motore Motor - Moteur MEC	h3	p	p1	p2	q	q1	r1	x1
KS 150-274F4 A3 S2	18,5	1450	180	120	1350	1150	100	600	564	18	1380
KS 150-279F4 A3 S2											1465
KS 150-240H A3 S2	30	1450	200	120	1350	1150	100	600	564	18	1465
KS 150-250H A3 S2											1520
KS 150-260H A3 S2											1520
KS 150-270H A3 S2	37	1450	225	120	1350	1150	100	600	564	18	1520
KS 150-279H A3 S2											1520

KS 150/4-280.3.19

Con riserva di variazioni tecniche e costruttive senza preavviso.
With reserve of technical and constructive variations without warning. - Avec réserve de variations techniques et constructives sans préavis.

POMPE ROTOMECC srl - 20063 CERNUSCO SUL NAVIGLIO (MI) - ITALY - Via Ponchielli,1

+39.02.92110205 - +39.02.92330399 +39.02.92110630 Sito Internet: www.pomperotomec.it E-mail: sales@pomperotomec.it



POMPE ROTOMECC

KS 150/4-375.1

DN 150

Giri/1' - r.p.m.
1450

Elettropompe centrifughe ad asse orizzontale con girante bicanale aperta e diffusore tagliante
Centrifugal horizontal pumps with channel impeller and cutting diffuser
Pompes à axe horizontal avec roue à canaux et anneau tranchant



UNI EN ISO 9001 - 2015

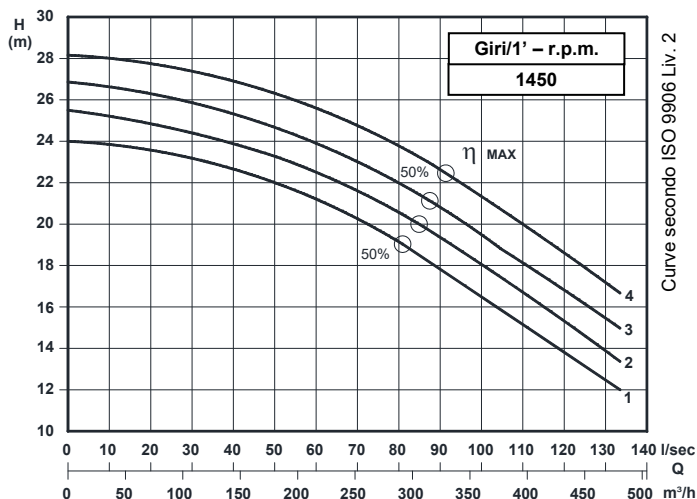

Curve secondo ISO 9906 Liv. 2

Grandezza - Size - Group 150/375

Curva Curve Courbe N°	Pompa Pump Pompe	DN	Potenza motore Motor power Puissance du moteur P2 (Kw)	Giri/1' r.p.m.	Passaggio libero Free passage Section de passage
1	KS 150-300K11 A4 S3	150	37	1450	120
2	KS 150-310K11 A4 S3		45		
3	KS 150-320K11 A4 S3				
4	KS 150-330K11 A4 S3				

P2 - Potenza resa - Shaft power - Puissance sur arbre

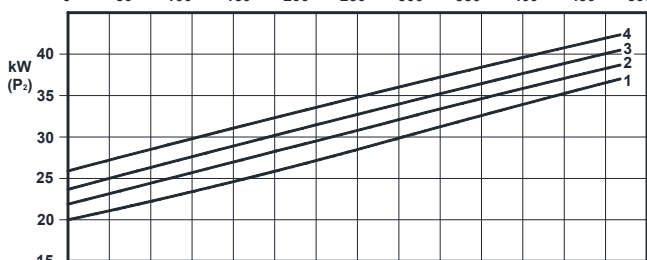

COSTRUZIONE - Materials - Matériaux

Fusioni principali - Principal parts - Parts principal	Ghisa - Cast iron - Fonte - GG 25
Girante - Impeller - Roue	Ghisa - Cast iron - Fonte - GS 500
Albero - Shaft - Arbre	AISI 420
Viteria - Screws - Vis	AISI 304

TENUTE MECCANICHE - Mechanical seals - Garniture mécanique

Doppia tenuta meccanica in bagno d'olio - Double mechanical seals in oil bath -
Double garniture mécanique en chambre d'huile
Tenuta lato motore / tenuta lato liquido : carburo di silicio
Motor side / liquid side mechanical seal : silicon carbide
Garniture mécanique côté du moteur / côté liquide : carbure de silicium

CARATTERISTICHE TECNICHE - Technical Features - Caractéristiques Techniques

Max. temperatura liquido - Max. liquid temp. - Max. temperature du liquide : 60°C
pH Liquido pompato - pH pumped liquid - pH du liquide pompé : 6 - 10

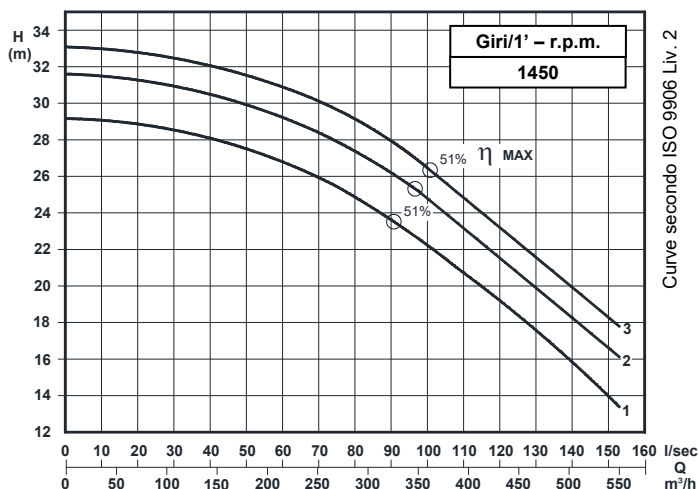

Curve secondo ISO 9906 Liv. 2

Grandezza - Size - Group 150/375

Curva Curve Courb e N°	Pompa Pump Pompe	DN	Potenza motore Motor power Puissance du moteur P2 (Kw)	Giri/1' r.p.m.	Passaggio libero Free passage Section de passage
1	KS 150-335K11 A4 S3	150	55	1450	120
2	KS 150-350K11 A4 S3				
3	KS 150-360K11 A4 S3				

P2 - Potenza resa - Shaft power - Puissance sur arbre

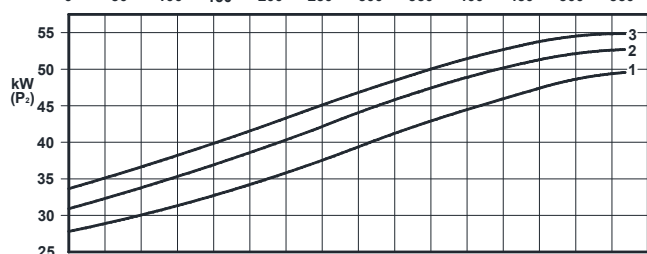

DIMENSIONI DI INGOMBRO - Dimensions

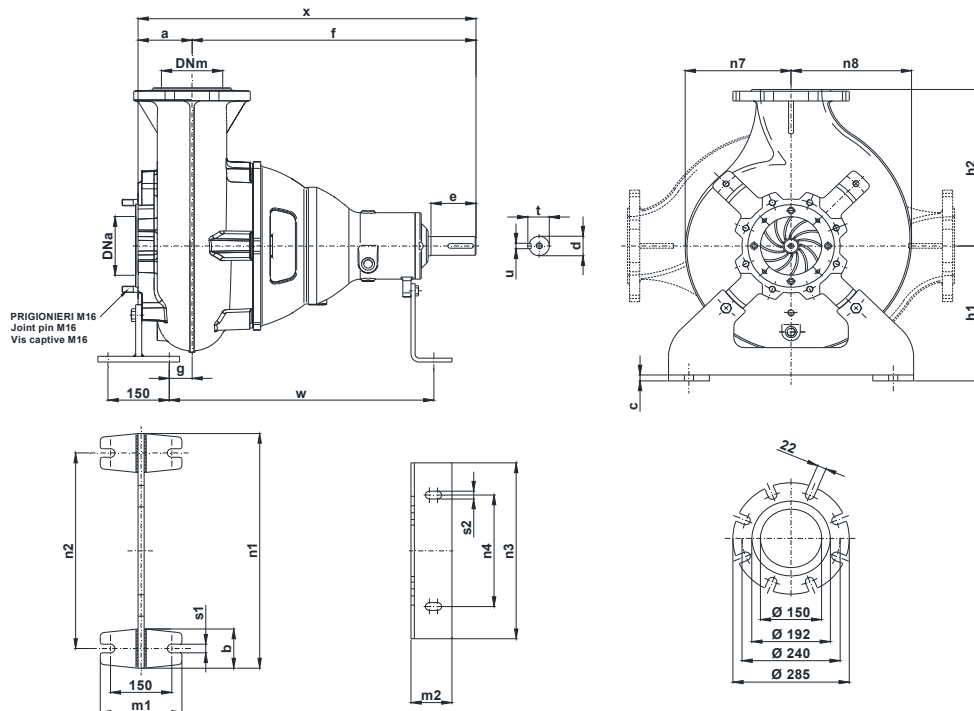

Pompa Pump Pompe	DNa DNm	a	b	c	d	e	f	g	h1	h2	m1	m2	n1	n2	n3	n4	n7	n8	s1	s2	t	u	v	w	x	Peso Weight Poids
KB 150 / .. A4S3	150	135	100	12	42	100	692	53	345	400	200	100	400	330	150	110	210	240	22	20	53	14	860	500	827	220

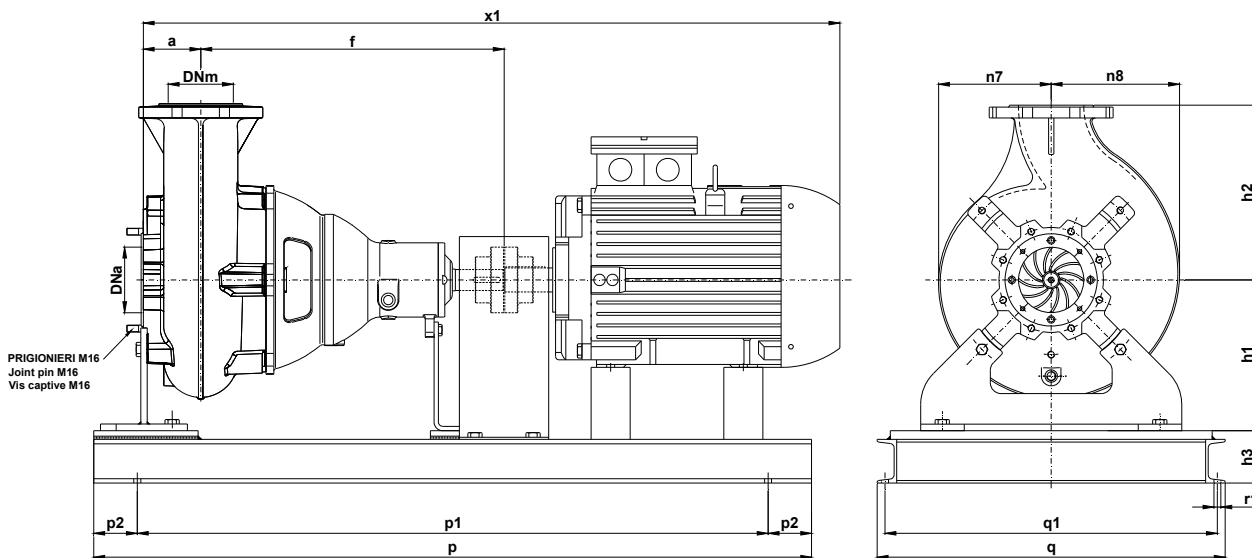

Pompa Pump Pompe	kW	Giri/1' r.p.m.	Motore Motor - Moteur MEC	h3	p	p1	p2	q	q1	r1	x1	Peso Weight Poids
KS 150-300K11 A4 S3	37	1450	225	120	1650	1450	100	600	564	16	1655	660
KS 150-310K11 A4 S3	45										1680	690
KS 150-320K11 A4 S3	55										1765	810
KS 150-330K11 A4 S3			250									
KS 150-335K11 A4 S3												
KS 150-350K11 A4 S3												
KS 150-360K11 A4 S3												

KB 150/4-375.1.19

Con riserva di variazioni tecniche e costruttive senza preavviso.
With reserve of technical and constructive variations without warning. - Avec réserve de variations techniques et constructives sans préavis.

POMPE ROTOMECC srl - 20063 CERNUSCO SUL NAVIGLIO (MI) - ITALY - Via Ponchielli,1

+39.02.92110205 - +039.02.92330399 +39.02.92110630 **Sito Internet:** www.pomperotomec.it **E-mail:** sales@pomperotomec.it