



# POMPE ROTOMECC

## RS 655-00.2

### DN 65

### 2900 rpm

Pompe sommergibili con girante arretrata a vortice  
*Submersible pumps with vortex impeller*  
*Electropompes submersibles avec roue vortex*

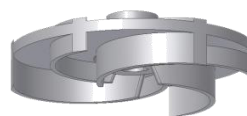

N°	CURVA - Curve - Courbe	POMPA Pump Pompe	GIRI /Min - RPM - Tours/min.	POTENZA RESA NOMINALE Rated power Puissance nominale (Pn)	ASSORBIMENTO NOMINALE Rated current Intensité nominale 400 V.	FATTORE DI POTENZA Power factor Facteur de puissance	TENSIONE - Voltage	CAVO - Cable	SONDE TERMICHE Thermal control Thermosondes	SENSORE INFILTRAZIONE Moisture sensor Detecteur de infiltration	PESO - Weight - Poids	INSTALLAZIONE - Installation F = FISSA - Fixed - Fixe M = MOBILE - Mobile - Portable
				kW	A	Cos. φ	3 ~ 50 Hz	H07RNF 10m			Kg	F M
1	RS 655/2 - 1165K2	2900	2900	5,5	11,5	0,82	400 V.	(1) 4G2,5 ● (1) 7G2,5 ■	○	○	77	○ ○
2	RS 655/2 - 1170K2											
3	RS 655/2 - 1175K2											

● Di serie - Standard    ■ Con protezioni - With protections - Avec sond    ○ A richiesta - On request - A la demande



**PASSAGGIO LIBERO**  
*Free passage - Section de passage*  
**45 mm**

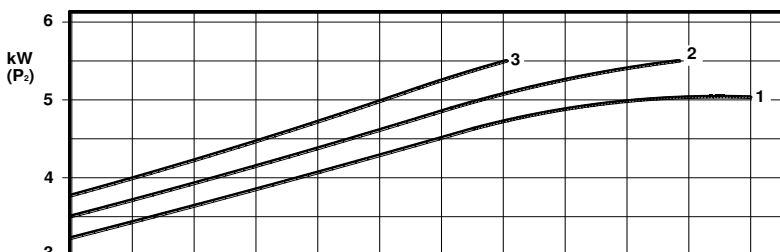
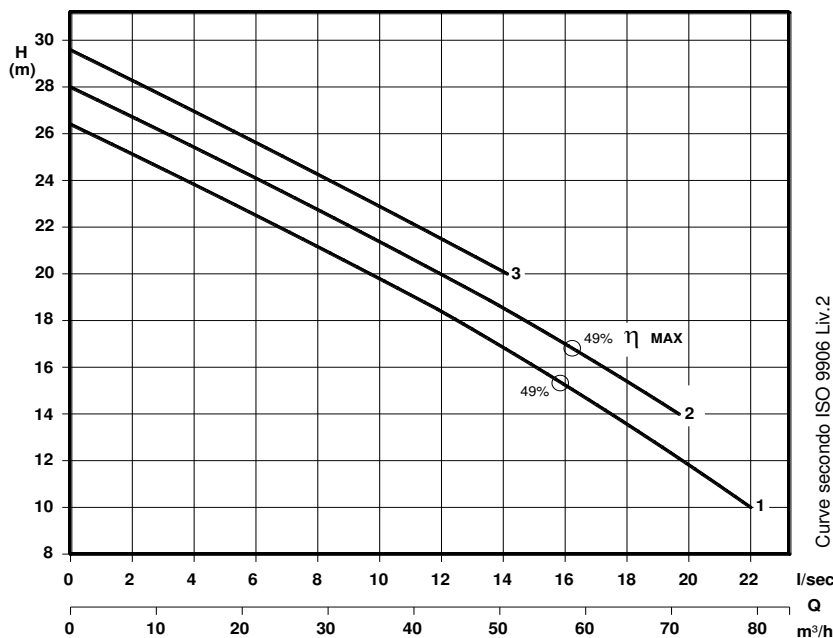

P<sub>2</sub> - Potenza resa - Shaft power - Puissance sur arbre

COSTRUZIONE - Materials - Matériaux	
Fusioni principali Principal parts Parts principal	Ghisa Cast iron - Fonte GG 25
Girante Impeller - Roue	Ghisa Cast iron - Fonte GG 25
Albero - Shaft - Arbre	AISI 420
Viteria - Screws - Vis	AISI 304
Motore - Motor - Moteur : IP68	
Classe isolamento - Insulating class : F	

### TENUTE MECCANICHE - Mechanical seals - Garniture mécanique

Doppia tenuta meccanica in bagno d'olio - *Double mechanical seals in oil bath - Double garniture mécanique en chambre d'huile*  
 Superiore - Upper - Supérieur : Grafite/Allumina - *Graphite/Alumina*  
 Inferiore - Lower - Inferieur : Carburo di silicio - *Silicon carbide*  
 Max. temperatura liquido: 40°C - *Max liquid temp. 40°C*  
 Max profondità di installazione - *Max installation depth*  
 Max profondità d'installazione = 20m.

**INSTALLAZIONE MOBILE - Mobile installation - Installation portable**

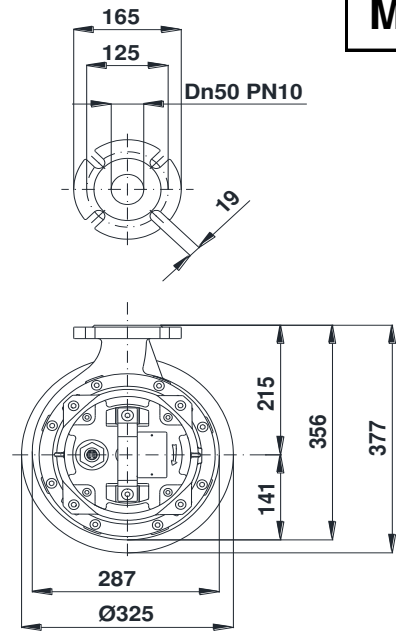
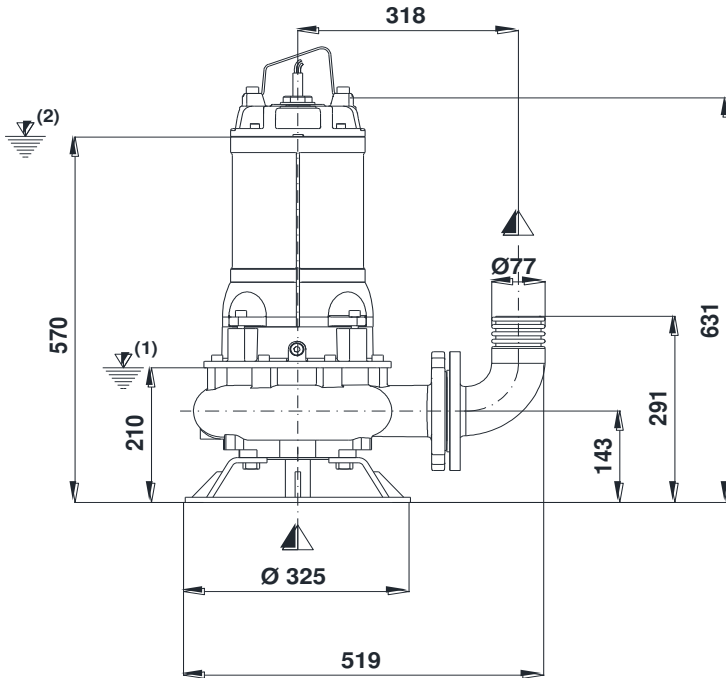

**M**

▼ (1) Livello minimo di arresto per funzionamento automatico.  
 Lowest shut-of level for automatic control.  
 Point d'arrêt plus bas pour service automatiques.

**INSTALLAZIONE FISSA - Fixed installation - Installation fixe**

Staffa fissaggio tubi guida  
 Upper guide rails bracket  
 Etrier supérieur pour tube de guidage

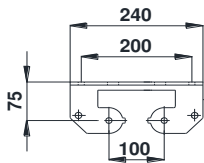

Tubo Guida  
 Pipe guide  
 Tube de guidage

DISPOSITIVO DI ACCOPIAMENTO -  
 Discharge connection bracket  
 Dispositif d'acouplement

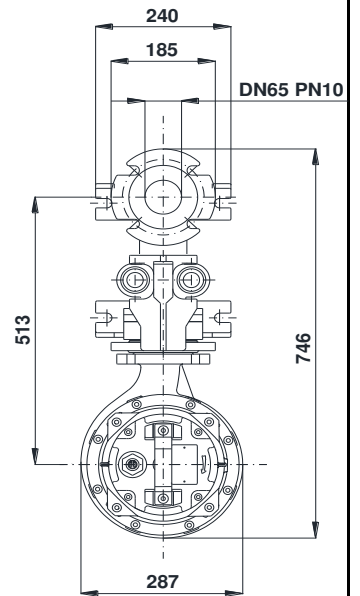
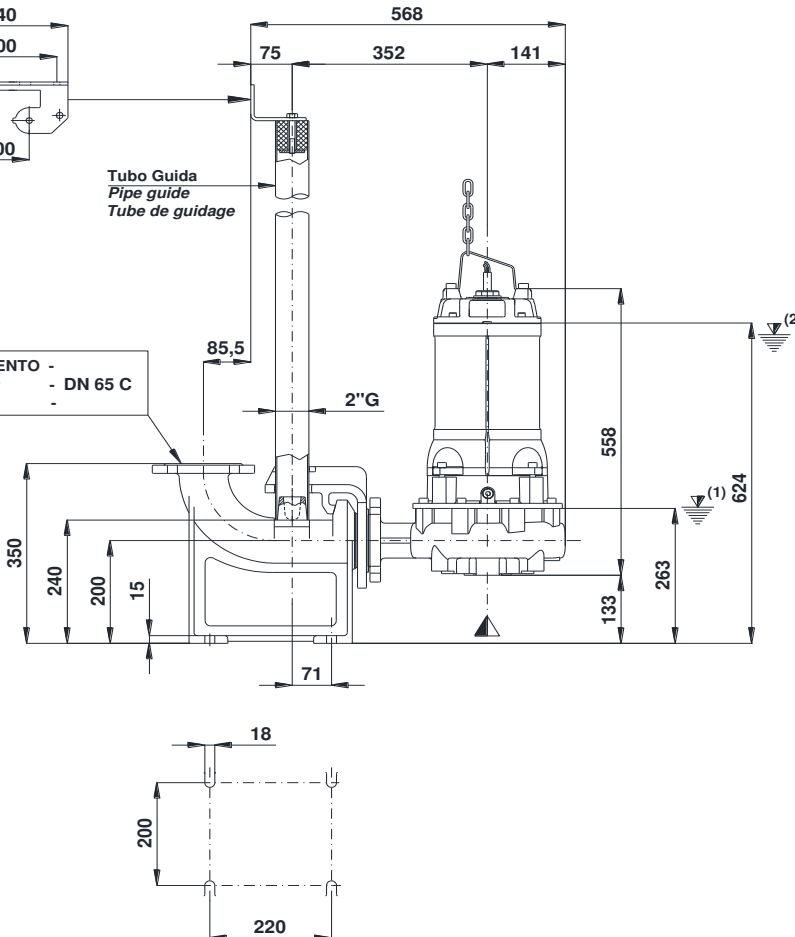

**F**

▼ (2) Sommergenza minima per funzionamento continuo.  
 Minimum covering level for continuous service.  
 Submersion minimal pour service continu.

RS 65-220-1-21X

Con riserva di variazioni tecniche e costruttive senza preavviso.

With reserve of technical and constructive variations without warning. Avec réserve de variations techniques et constructives sans préavis

**POMPE ROTOMECC s.r.l.** - 20063 CERNUSCO SUL NAVIGLIO (MI) - ITALY - Via Ponchielli, 1

Tel. +39.02.9211.0205 - +39.02.9233.0399 Fax 02 9211.0630 Sito Internet: [www.pomperotomec.it](http://www.pomperotomec.it) E-mail: [sales@pomperotomec.it](mailto:sales@pomperotomec.it)



# POMPE ROTOMECC

## RS 656-10.2

### DN 65

### 2900 rpm

Pompe sommergibili con girante arretrata a vortice  
*Submersible pumps with vortex impeller*  
*Electropompes submersibles avec roue vortex*



N°	CURVA - Curve - Courbe	POMPA Pump Pompe	GIRI /Min - RPM - Tours/min.	POTENZA RESA NOMINALE Rated power Puissance nominale (P <sub>2</sub> )	ASSORBIMENTO NOMINALE Rated current Intensité nominale	FATTORE DI POTENZA Power factor Facteur de puissance	TENSIONE - Voltage	CAVO - Cable	SONDE TERMICHE Thermal control Thermosondes	SENSORE INFILTRAZIONE Moisture sensor Detecteur de infiltration	PESO - Weight - Poids	INSTALLAZIONE - Installation F = FISSA - Fixed - Fixe M = MOBILE - Mobile - Portable
				kW	A	Cos. φ	3 ~ 50 Hz	H07RNF 10m			Kg	F M
1	RS 656/2 - 1165K3	2900	2900	6,7	14,5	0,82	400 V.	(1) 4G2,5 ● (1) 7G2,5 ■	○	○	90	○ ○
2	RS 656/2 - 1170K3											
3	RS 656/2 - 1175K3											
4	RS 656/2 - 1180K3											
5	RS 656/2 - 1185K3											
6	RS 656/2 - 1190K3											

● Di serie - Standard    ■ Con protezioni - With protections - Avec sonde    ○ A richiesta - On request - A la demande



**PASSAGGIO LIBERO**  
*Free passage - Section de passage*  
**50 mm**

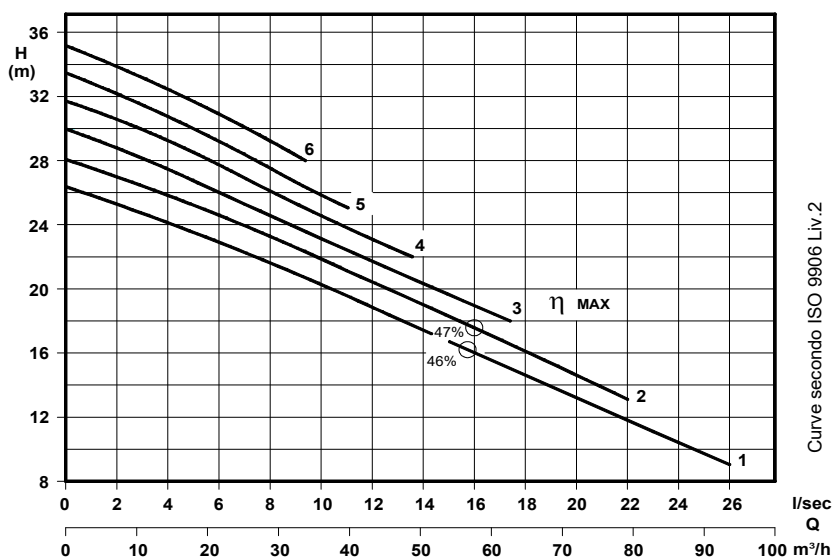

Curve secondo ISO 9906 Liv.2

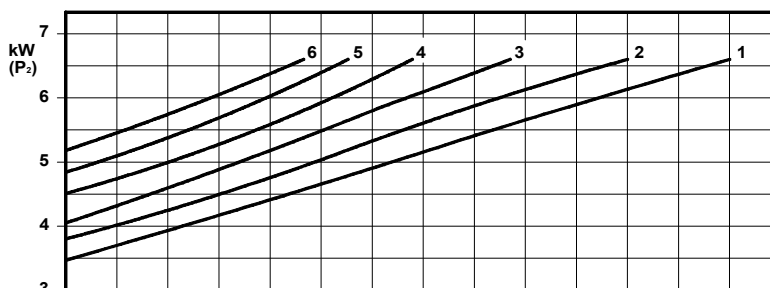

P<sub>2</sub> - Potenza resa - Shaft power - Puissance sur arbre

COSTRUZIONE - Materials - Matériaux	
Fusioni principali <i>Principal parts</i> <i>Parts principal</i>	Ghisa Cast iron - Fonte GG 25
Girante <i>Impeller - Roue</i>	Ghisa Cast iron - Fonte GG 25
Albero - Shaft - Arbre	AISI 420
Viteria - Screws - Vis	AISI 304
Motore - Motor - Moteur : IP68	
Classe isolamento - Insulating class : F	

### TENUTE MECCANICHE - Mechanical seals - Garniture mécanique

Doppia tenuta meccanica in bagno d'olio - *Double mechanical seals in oil bath - Double garniture mécanique en chambre d'huile*  
 Superiore - Upper - Supérieur : Grafite/Allumina - *Graphite/Alumina*  
 Inferiore - Lower - Inferieur : Carburo di silicio - *Silicon carbide*

Max. temperatura liquido: 40°C - *Max liquid temp. 40°C*

Max profondità di installazione - *Max installation depth*

Max profondità d'installazione = 20m.

**INSTALLAZIONE MOBILE - *Mobile installation - Installation portable***

**M**

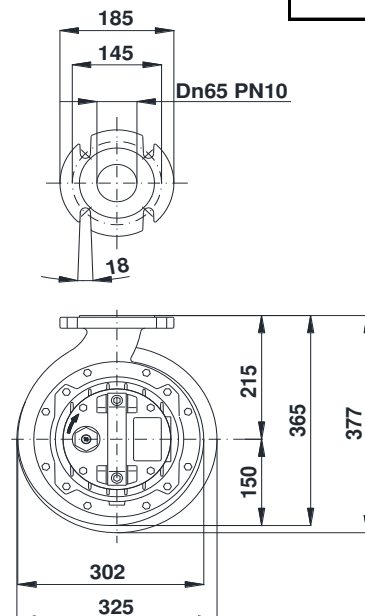
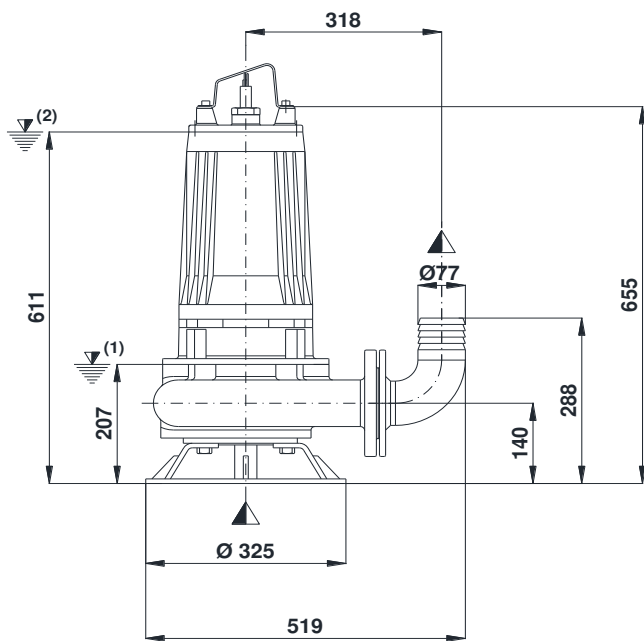

(1) Livello minimo di arresto per funzionamento automatico.  
 Lowest shut-of level for automatic control.  
 Point d'arrêt plus bas pour service automatiques.

**INSTALLAZIONE FISSA - *Fixed installation - Installation fixe***

(2) Sommergenza minima per funzionamento continuo.  
 Minimum covering level for continuous service.  
 Submersion minimal pour service continu.

Staffa fissaggio tubi guida  
 Upper guide rails bracket  
 Etrier supérieur pour tube de guidage

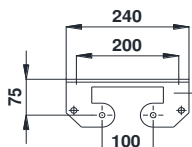

Tubo Guida  
 Pipe guide  
 Tube de guidage

DISPOSITIVO DI ACCOPPIAMENTO -  
 Discharge connection bracket  
 Dispositif d'accouplement

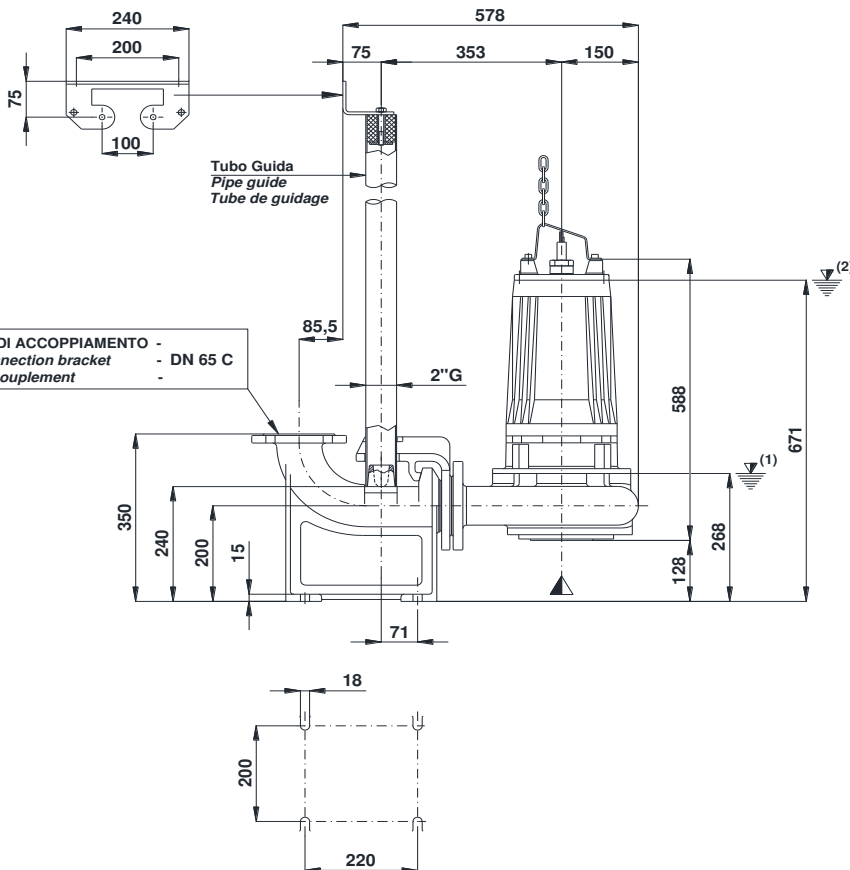

**F**

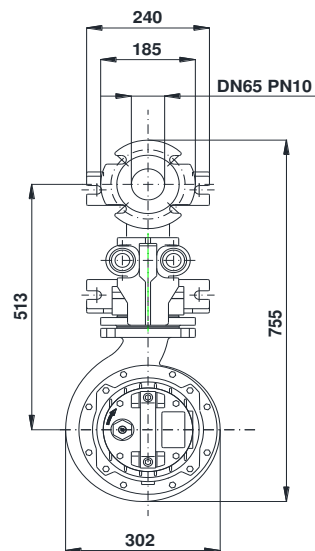



# POMPE ROTOMECC

## RS 659-11.2

### DN 65

### 2900 rpm

Pompe sommergibili con girante arretrata a vortice  
*Submersible pumps with vortex impeller*  
*Electropompes submersibles avec roue vortex*

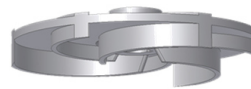

N°	CURVA - Curve - Courbe	POMPA Pump Pompe	GIRI/Min - RpM - Tours/min.	POTENZA RESA NOMINALE Rated power Puissance nominale (P <sub>2</sub> )	ASSORBIMENTO NOMINALE Rated current Intensité nominale 400 V.	FATTORE DI POTENZA Power factor Facteur de puissance	TENSIONE - Voltage	CAVO - Cable	SONDE TERMICHE Thermal control Thermosondes	SENSORE INFILTRAZIONE Moisture sensor Detecteur de infiltration	PESO - Weight - Poids	INSTALLAZIONE - Installation F = FISSA - Fixed - Fixe M = MOBILE - Mobile - Portable
				kW	A	Cos. φ	3 ~ 50 Hz	H07RNF 10m			Kg	F M
1	RS 659/2 - 1175	2900	2900	9,8	21	0,82	400/700 V.	(1) 10G2,5	●	○	145	○ ○
2	RS 659/2 - 1185											
3	RS 659/2 - 1195											
4	RS 659/2 - 1205											

● Di serie - Standard

○ A richiesta - On request - A la demande



**PASSAGGIO LIBERO**  
*Free passage - Section de passage*  
**45 mm**

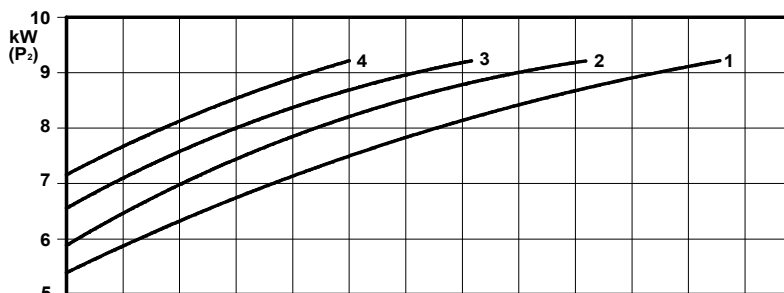
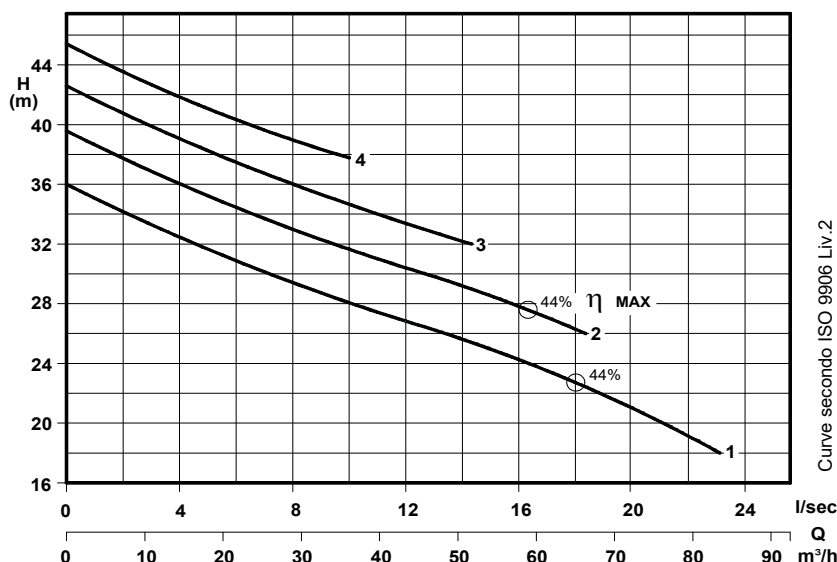

P<sub>2</sub> - Potenza resa - Shaft power - Puissance sur arbre

COSTRUZIONE - Materials - Matériaux	
Fusioni principali <i>Principal parts</i> <i>Parts principal</i>	Ghisa Cast iron - Fonte GG 25
Girante <i>Impeller - Roue</i>	Ghisa Cast iron - Fonte GG 25
Albero - Shaft - Arbre	AISI 420
Viteria - Screws - Vis	AISI 304
Motore - Motor - Moteur : IP68	
Classe isolamento - Insulating class: F	

### TENUTE MECCANICHE - Mechanical seals - Garniture mécanique

Doppia tenuta meccanica in bagno d'olio - *Double mechanical seals in oil bath - Double garniture mécanique en chambre d'huile*  
 Superiore - Upper - Supérieur : Grafite/Allumina - *Graphite/Alumina*  
 Inferiore - Lower - Inferieur : Carburo di silicio - *Silicon carbide*  
 Max. temperatura liquido: 40°C - *Max liquid temp. 40°C*  
 Max profondità di installazione - *Max installation depth*  
 Max profondità d'installazione = 20m.

**INSTALLAZIONE MOBILE - *Mobile installation - Installation portable***

**M**

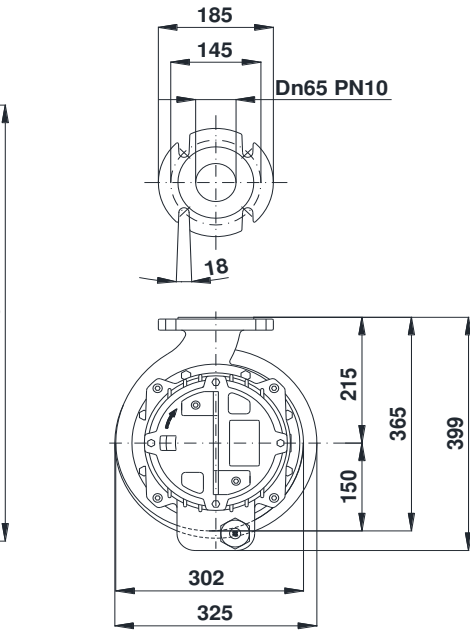
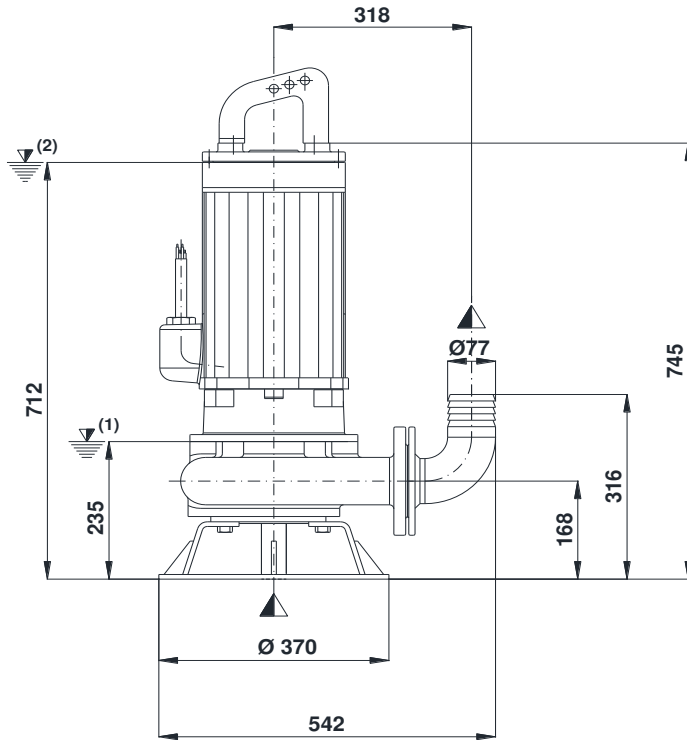

(1) Livello minimo di arresto per funzionamento automatico.  
 Lowest shut-of level for automatic control.  
 Point d'arrêt plus bas pour service automatiques.

**INSTALLAZIONE FISSA - *Fixed installation - Installation fixe***

(2) Sommergenza minima per funzionamento continuo.  
 Minimum covering level for continuous service.  
 Submersion minimal pour service continuu.

Staffa fissaggio tubi guida  
 Upper guide rails bracket  
 Etrier supérieur pour tube de guidage

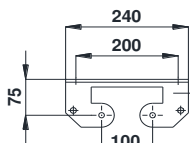

Tubo Guida  
 Pipe guide  
 Tube de guidage

DISPOSITIVO DI ACCOPIAMENTO -  
 Discharge connection bracket  
 Dispositif d'accouplement

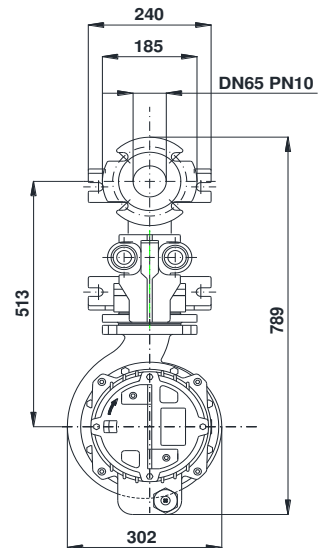
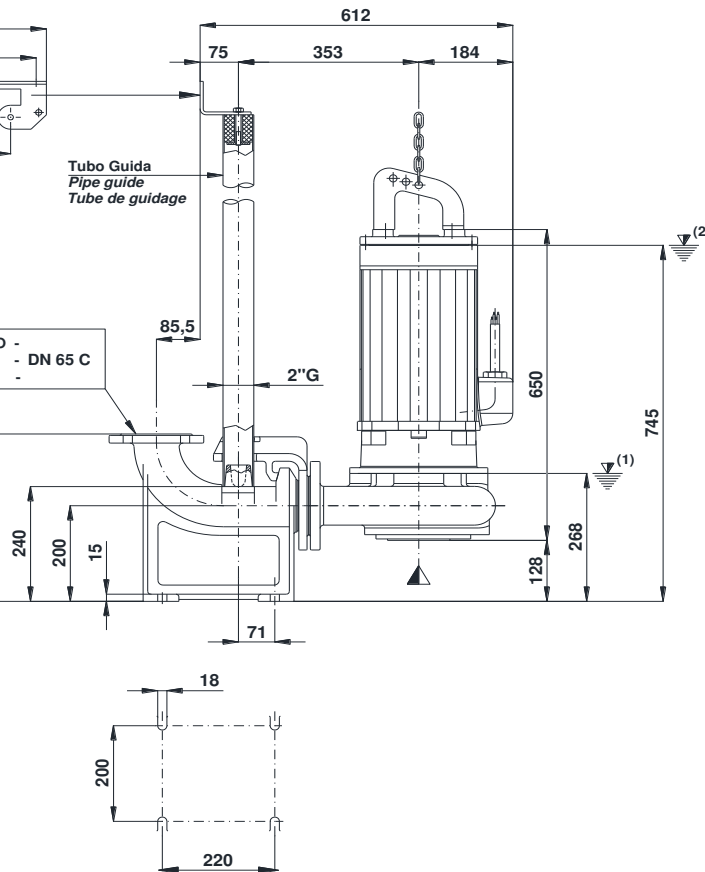

**F**





# POMPE ROTOMECC

## RS 6513-12.2

### DN 65

### 2900 rpm

Pompe sommergibili con girante arretrata a vortice  
*Submersible pumps with vortex impeller*  
*Electropompes submersibles avec roue vortex*

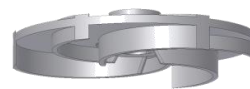

N°	CURVA - Curve - Courbe	POMPA Pump Pompe	GIRI/Min - RPM - Tours/min.	POTENZA RESA NOMINALE Rated power Puissance nominale (Pn)	ASSORBIMENTO NOMINALE Rated current Intensité nominale 400 V.	FATTORE DI POTENZA Power factor Facteur de puissance	TENSIONE - Voltage	CAVO - Cable	SONDE TERMICHE Thermal control Thermosondes	SENSORE INFILTRAZIONE Moisture sensor Detecteur de infiltration	PESO - Weight - Poids	INSTALLAZIONE - Installation F = FISSA - Fixed - Fixe M = MOBILE - Mobile - Portable
				kW	A	Cos. φ	3 ~ 50 Hz	H07RNF 10m			Kg	F M
1	RS 6513/2 - 1195		2900	13,5	26,5	0,82	400/700 V.	(1) 10G2,5	●	○	145	○ ○
2	RS 6513/2 - 1200											
3	RS 6513/2 - 1210											
4	RS 6513/2 - 1215											
5	RS 6513/2 - 1219											

● Di serie - Standard

○ Con protezioni - With protections - Avec sondes



**PASSAGGIO LIBERO**  
*Free passage - Section de passage*  
**45 mm**

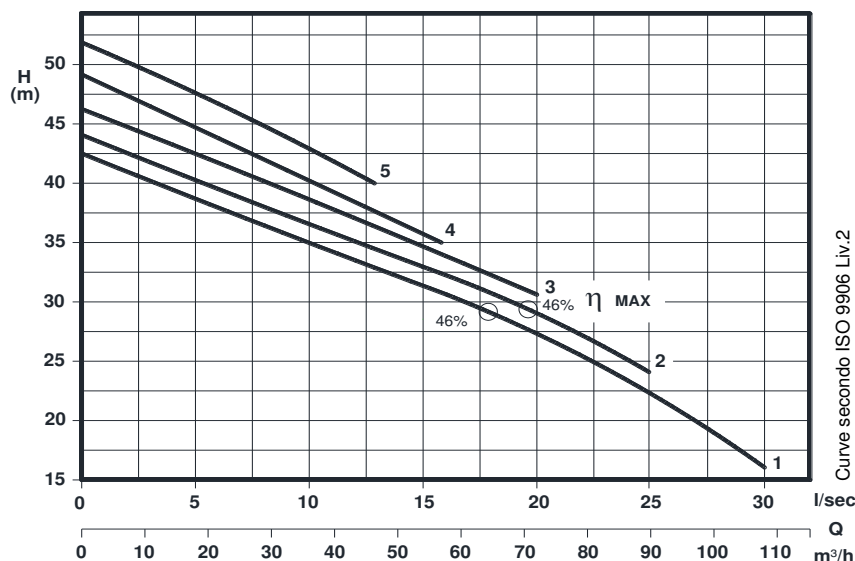

Curve secondo ISO 9906 Liv.2

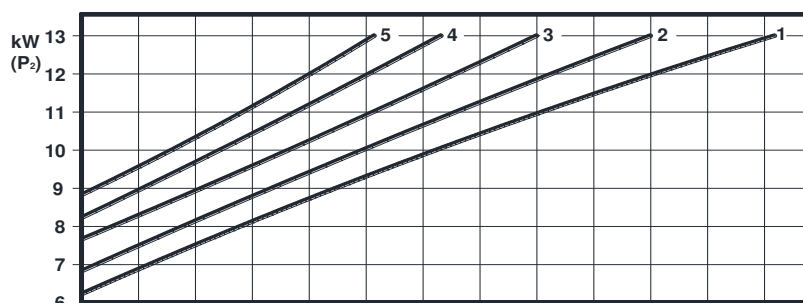

P<sub>2</sub> - Potenza resa - Shaft power - Puissance sur arbre

COSTRUZIONE - Materials - Matériaux	
Fusioni principali <i>Principal parts</i> <i>Parts principal</i>	Ghisa Cast iron - Fonte GG 25
Girante <i>Impeller - Roue</i>	Ghisa Cast iron - Fonte GG 25
Albero - Shaft - Arbre	AISI 420
Viteria - Screws - Vis	AISI 304
Motore - Motor - Moteur : IP68	
Classe isolamento - Insulating class : F	

### TENUTE MECCANICHE - Mechanical seals - Garniture mécanique

Doppia tenuta meccanica in bagno d'olio - *Double mechanical seals in oil bath - Double garniture mécanique en chambre d'huile*  
 Superiore - Upper - Supérieur : Grafite/Allumina - *Graphite/Alumina*  
 Inferiore - Lower - Inferieur : Carburo di silicio - *Silicon carbide*  
 Max. temperatura liquido: 40°C - *Max liquid temp. 40°C*  
 Max profondità di installazione - *Max installation depth*  
 Max profondità d'installazione = 20m.

**INSTALLAZIONE MOBILE - *Mobile installation - Installation portable***

**M**

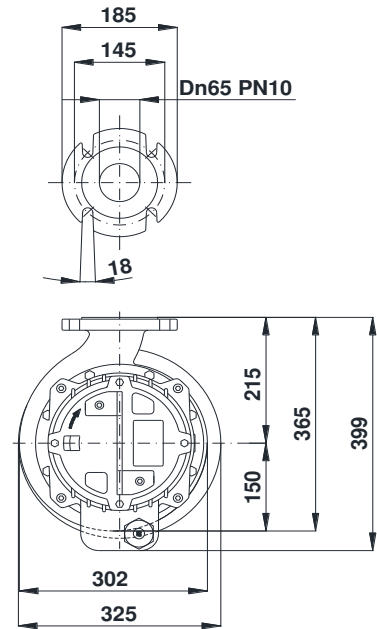
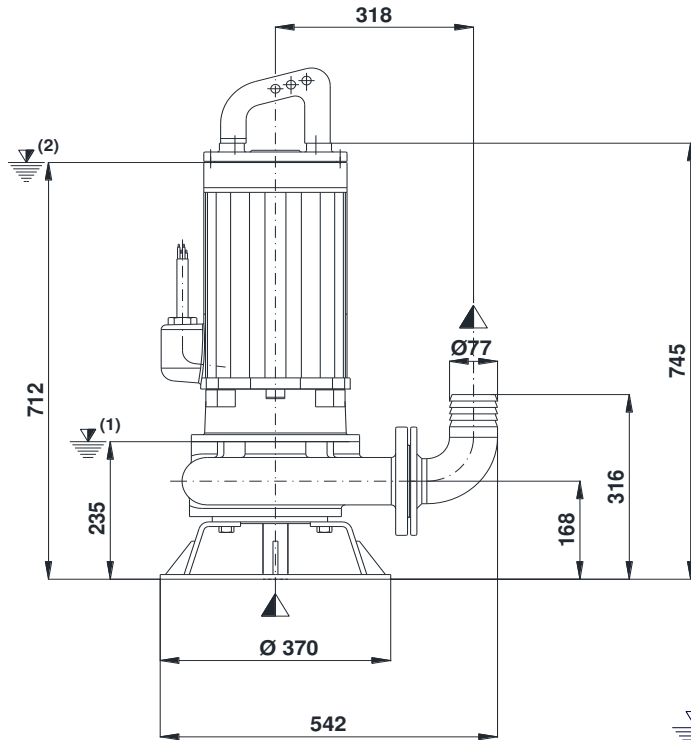

(1) Livello minimo di arresto per funzionamento automatico  
 Lowest shut-of level for automatic control.  
 Point d'arrêt plus bas pour service automatiques.

**INSTALLAZIONE FISSA - *Fixed installation - Installation fixe***

(2) Sommergenza minima per funzionamento continuo  
 Minimum covering level for continuous service.  
 Submersion minimal pour service continu.

Staffa fissaggio tubi guida  
 Upper guide rails bracket  
 Etrier supérieur pour tube de guidage

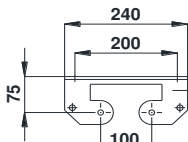

Tubo Guida  
 Pipe guide  
 Tube de guidage

DISPOSITIVO DI ACCOPPIAMENTO -  
 Discharge connection bracket - DN 65 C  
 Dispositif d'acouplement

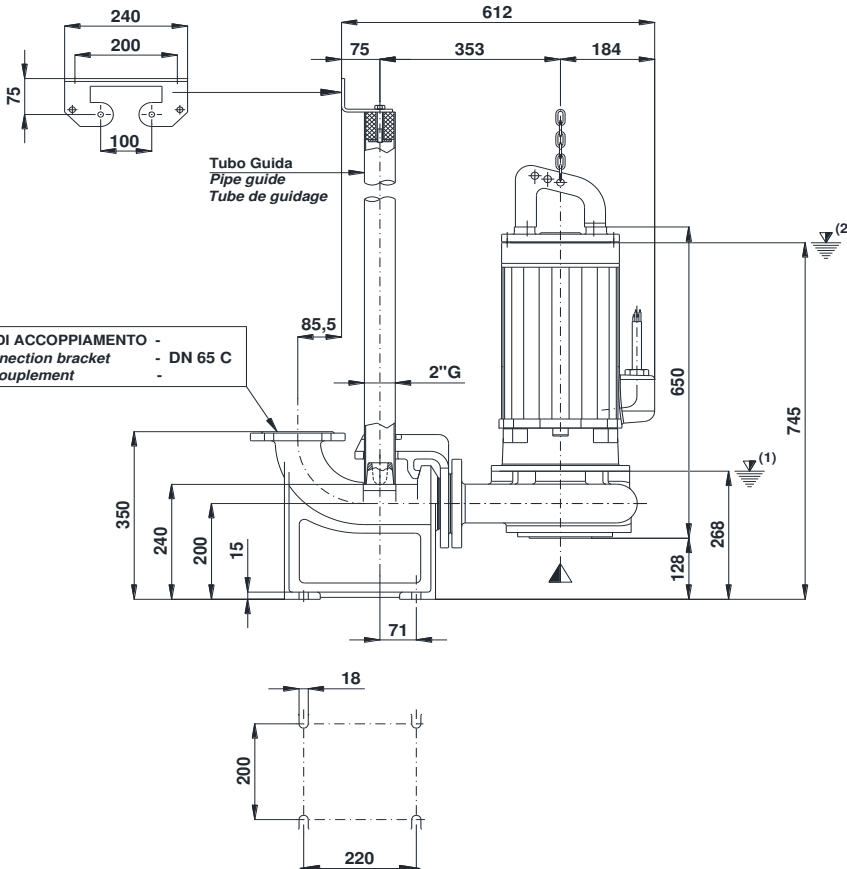

**F**

